

## IMPORTANT SHOW INFORMATION

We are pleased to announce that GES has been selected as the Official General Services Contractor for your event. Our goal is to help ensure that your show participation is a success.

Please review our payment policy carefully. As a reminder, GES requires payment **in full** at the time you place your order, along with the credit card authorization. This may be used to cover items such as labour and material handling, not included with your initial payment. In addition, any unpaid charges at the end of the event will be charged to the supplied credit card as per GES terms and conditions.

**Take advantage of our substantial price discounts!** Just return your order with payment by the advance price deadline(s) on the order forms and use the lower price.

**For your convenience, we will be offering the following services:**

- |                     |                              |                                   |
|---------------------|------------------------------|-----------------------------------|
| - FURNISHINGS       | - SPECIALITY FURNISHINGS     | - CARPET & UNDERPADDING           |
| - GEM SHOW SPECIALS | - GEM EXHIBITS & ACCESSORIES | - PLANTS                          |
| - BOOTH CLEANING    | - SIGNS & GRAPHICS           | - INSTALLATION & DISMANTLE LABOUR |
| - IN-BOOTH FORKLIFT | - MATERIAL HANDLING          | - GES LOGISTICS & CUSTOMS         |

### PLEASE NOTE THE FOLLOWING INFORMATION REGARDING YOUR EVENT

GES ACCOUNT MANAGER: Evans Chan		GES EXHIBITOR SERVICES: Erika Imada	
<b>SHOW NAME</b> VRIC 2014		<b>SHOW DATES</b> January 19-20, 2014	
		<b>LOCATION</b> VCC-West Hall ABC	
<b>YOUR EXHIBIT BOOTH INCLUDES THE FOLLOWING ITEMS</b>			<b>BOOTH SIZE:</b> 10x10
8' High Backwall	3' sidewings	2 - Side Chairs	
1 - Wastebasket	1 - Booth ID Sign	1 - 6' Skirted Table	
750 Watt Outlet (VCC)			
KEY SHOW DATES & TIMES			
<b>DISCOUNT PRICE DEADLINE DATE:</b>	Friday, January 03, 2014	<i><u>TAKE ADVANTAGE OF 40% SAVINGS</u></i>	
<b>ADVANCE WAREHOUSE OPEN TO RECEIVE SHIPMENTS:</b>	Friday, December 20, 2013	<b>ADVANCE SHIPMENTS MAY START BEING RECEIVED AT THE ADVANCE</b>	
<b>ADVANCE WAREHOUSE CLOSES TO SHIPMENTS:</b>	Tuesday, January 15, 2013	<b>ALL SHIPMENTS AFTER THIS DATE NEED TO BE DIRECT TO SHOWSITE.</b>	
<b>DIRECT TO SHOW SITE SHIPMENT WILL BE RECEIVED:</b>	Saturday, January 18, 2014	<b>FIRST DAY DIRECT TO SHOWSITE SHIPMENTS WILL BE RECEIVED.</b>	
<b>FIRST DAY OF GENERAL EXHIBITOR MOVE-IN:</b>	Saturday, January 18, 2014	FROM	2:00PM - 6:00PM
<b>LAST DAY OF GENERAL EXHIBITOR MOVE-IN:</b>	Sunday, January 19, 2014	FROM	8:00AM - 10:00AM
<b>SHOW HOURS</b>	Sunday, January 19, 2014	10:00AM - 5:00PM	
	Monday, January 20, 2014	10:00AM - 5:00PM	
<b>GENERAL EXHIBITOR MOVE OUT BEGINS:</b>	Monday, January 20, 2014	FROM	5:00PM - 8:00PM
<b>EXHIBITOR MOVE OUT ENDS / FORCED FREIGHT</b>	Monday, January 20, 2014	AT	8:00PM

**Please call or email our team at the numbers listed below with any questions or concerns. Our team is ready and willing to assist you with all your show services related needs.**

Phone: 778.452.6220 Fax: 778.452.6221 Toll Free: 855.526.7182 [vancouvercustomerservice@ges.com](mailto:vancouvercustomerservice@ges.com)

<b>SHOW NAME:</b>	<b>VRIC 2014</b>	<b>DISCOUNT PRICE</b>	Friday, January 03, 2014
<b>SHOW DATE:</b>	<b>January 19-20, 2014</b>	<b>DEADLINE DATE:</b>	

**TO:** **GES VANCOUVER**  
**FAX:** **778-452-6221**  
**EMAIL:** [vancouvercustomerservice@ges.com](mailto:vancouvercustomerservice@ges.com)  
**DATE:** \_\_\_\_\_  
**FROM:** \_\_\_\_\_  
**COMPANY:** \_\_\_\_\_  
**PHONE:** \_\_\_\_\_  
**EMAIL:** \_\_\_\_\_  
**SHOW NAME:** \_\_\_\_\_  
**BOOTH #:** \_\_\_\_\_



To help us ensure we have received your entire order and we have the correct totals, check off those forms you are sending us and complete value section for each form

	<b>GES ORDER FORM (s)</b>	<b>Pg. Total</b>
<input type="checkbox"/>	Credit Card Authorization	
<input type="checkbox"/>	Third Party Billing	
<input type="checkbox"/>	Furnishings	
<input type="checkbox"/>	Speciality Furnishings	
<input type="checkbox"/>	Carpet & Underpad	
<input type="checkbox"/>	GEM Exhibit Rentals	
<input type="checkbox"/>	GEM Exhibit Accessories	
<input type="checkbox"/>	Graphics	
<input type="checkbox"/>	Plants	
<input type="checkbox"/>	Installation & Dismantle Services	
<input type="checkbox"/>	Booth Cleaning	
<input type="checkbox"/>	Material Handling	
<input type="checkbox"/>	GES Logistics / GES Customs	
<input type="checkbox"/>	Electrical	

*Please call to confirm receipt of your order.*

To receive Discount Pricing send your order in by the Discount Price Deadline Date noted above.



**THANK YOU FROM GES**

**SHOW NAME:****VRIC 2014****DISCOUNT PRICE****DEADLINE DATE:**

Friday, January 03, 2014

**SHOW DATE:****January 19-20, 2014****Discount Pricing:**

To qualify for **Discount Pricing**, orders must be received **with payment in full on or before the deadline date**. Late orders will be charged the **Regular Price**. Orders without payment cannot be processed until payment is received and may be charged the **Regular Price**.

**Method of Payment:**

GES accepts American Express, MasterCard, Visa, Cheque and Bank Wire Transfers. Purchase Orders are not considered payment. **Exhibitors will be charged a \$25.00 fee for returned NSF cheques.**

**Bank Wire Transfer Information:**

To properly credit your account, please complete the **BANK WIRE TRANSFER FORM**, available upon request, and send the following information to the GES Exposition Services (Canada) Limited address listed on the Bank Wire Transfer Form.

**NOTE: There is a minimum \$20.00 Service Charge (North America) & \$40.00 (International) applicable on all wire transfers. Fees vary depending on banks processing wire transfers. Also, wire transfers can take 3 to 10 business days to be cleared. Ensure you leave enough time to receive the benefit of the discount. Orders are not processed until payment is received, this includes wire transfers.**

**PAYMENT SCHEDULE:**

Payment for all services must be pre-paid in full. GES will not provide Material Handling, In-Booth Forklifts, or Installation and Dismantle Labour Services without a company's **CREDIT CARD AUTHORIZATION FORM** on file.

**THIRD PARTY BILLING:**

Arrangements can be made for an exhibit house or other agent to manage exhibit & order services. GES will agree to this arrangement if the exhibit house or agent makes satisfactory payment arrangements prior to start of move-in. In the event the authorized Third Party does not pay, the exhibiting company is ultimately responsible for all charges incurred on its behalf. See **THIRD PARTY BILLING REQUEST FORM**.

**ADJUSTMENTS AND CANCELLATIONS:**

Adjustments to invoice(s) **will not be made after the close of the show**. Some items, services and labour are subject to cancellation fees. Refer to each order form for details.

**EXHIBITORS MUST PAY APPLICABLE TAXES ON ALL ORDERS.**

**EXHIBITORS ARE RESPONSIBLE FOR ANY UNPAID ORDERS. ALL ORDERS MUST BE PAID IN FULL PRIOR TO RELEASE OF GOODS FROM THE SHOW FLOOR**



## Accelerate your experience with Expresso exhibit planning, ordering and management.

Exhibitors can order everything they need for their tradeshow exhibit through Expresso, our simple to navigate, picture-driven system that satisfies your need for speed. With just a few clicks exhibitors can order GES products and services including:

- Booth furniture.
- Carpet and flooring.
- Material handling.
- Booth labour.
- And much more.

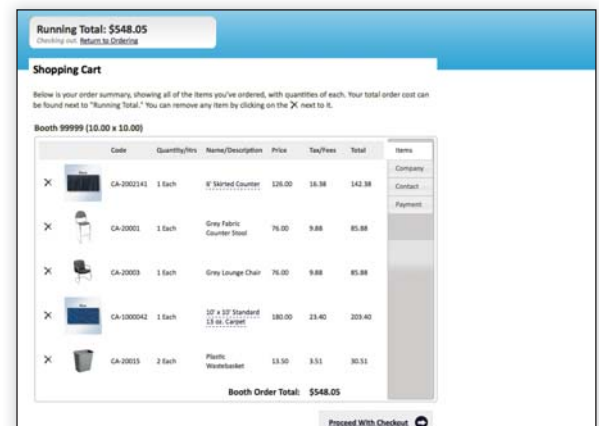
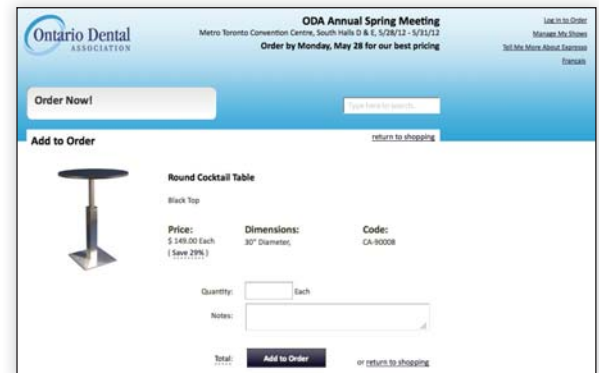

**Expresso is more than just an online exhibitor manual. Exhibitors can:**

- Order exhibit products and services.
- Print shipping labels.
- View important show and event information.
- Download the show schedule into Outlook or iCalendar.
- View account order status and history.

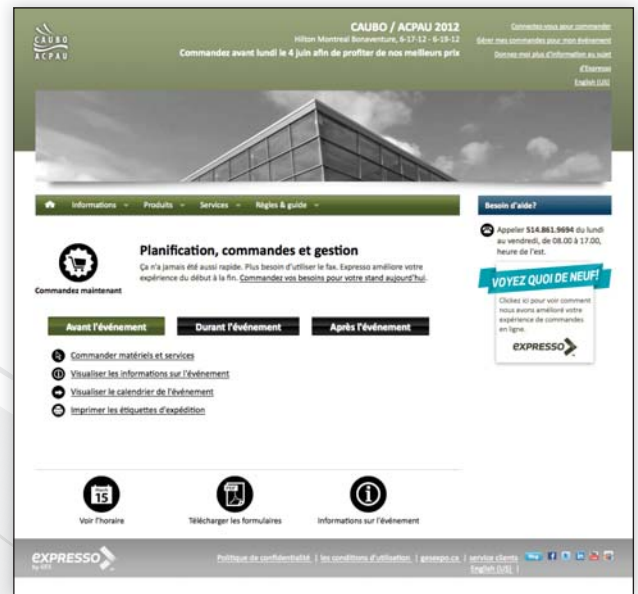

**Experience a difference with Expresso.**

- Each show has their own custom website.
- Runs on all browsers for PCs, Macs and tablets.
- Everything in one place; all organizer and show information, ordering and even third party forms.
- Keeps you on-time and on-budget.



# CREDIT CARD AUTHORIZATION FORM

SHOW NAME: **VRIC 2014**  
 SHOW DATE: **January 19-20, 2014**

DISCOUNT PRICE  
 DEADLINE DATE: **Friday, January 03, 2014**

**EXHIBITOR INFORMATION** **IMPORTANT - READ CAREFULLY**

BOOTH #: \_\_\_\_\_

COMPANY: \_\_\_\_\_

STREET: \_\_\_\_\_

CITY: \_\_\_\_\_ PROV/STATE: \_\_\_\_\_ CODE: \_\_\_\_\_

EMAIL: \_\_\_\_\_

PHONE: \_\_\_\_\_ FAX: \_\_\_\_\_

CONTACT NAME: \_\_\_\_\_

PLEASE FILL OUT THE CREDIT CARD AUTHORIZATION BELOW IF:

- Paying by Credit Card for any service.
- Payment is being forwarded to GES in the form of a cheque.
- There is any possibility that additional service(s) will be ordered on-site.
- Material Handling, Installation and Dismantle Labour or In-Booth Forklift Services will be required.

## PLEASE COMPLETE THE FOLLOWING

VISA     
  AMERICAN EXPRESS     
  MASTERCARD     
 EXPIRY DATE:

TYPE OF CARD     
  PERSONAL     
  CORPORATE

CARD #

CARDHOLDER'S NAME (PRINT): \_\_\_\_\_

CARDHOLDER'S SIGNATURE: \_\_\_\_\_

CARDHOLDER'S BILLING ADDRESS: \_\_\_\_\_

CITY: \_\_\_\_\_ PROV/STATE: \_\_\_\_\_ CODE/ZIP: \_\_\_\_\_

TELEPHONE: \_\_\_\_\_ FAX: \_\_\_\_\_

This authorization allows GES to charge any fees outstanding after show closing to this credit card.  
 (including funds owed due to a cheque returned NSF)

**CHEQUES WILL NOT BE ACCEPTED WITHOUT THIS CREDIT CARD AUTHORIZATION**

**IF THIS AUTHORIZATION IS NOT COMPLETED, ALL ON-SITE ORDERS ARE EXPECTED TO BE PAID IN FULL BEFORE DELIVERY**

**PLEASE SEE NOTE REGARDING GES TERMS AND CONDITIONS BELOW**

All equipment rental orders placed with GES are bound by the terms and conditions specific to each rental order form, material handling terms and conditions and GES standard terms and conditions located at the back of this kit. By signing below, you agree to all these terms and conditions. Without an authorized signature and date below, your order will not be processed.

I HAVE READ AND UNDERSTAND THE TERMS & CONDITIONS OF MY AGREEMENT WITH GES.

\_\_\_\_\_  
 Signature Print Name & Title Date



SHOW NAME: **VRIC 2014** DISCOUNT PRICE  
 SHOW DATE: **January 19-20, 2014** DEADLINE DATE: **Friday, January 03, 2014**

**EXHIBITOR INFORMATION**

**IMPORTANT - READ CAREFULLY**

BOOTH #: \_\_\_\_\_  
 COMPANY: \_\_\_\_\_  
 STREET: \_\_\_\_\_  
 CITY: \_\_\_\_\_ PROV/STATE: \_\_\_\_\_ CODE: \_\_\_\_\_  
 EMAIL: \_\_\_\_\_  
 PHONE: \_\_\_\_\_ FAX: \_\_\_\_\_  
 CONTACT NAME: \_\_\_\_\_

An exhibit house or other third party agent may handle display and booth arrangements and be charged for services. GES will agree to this arrangement if the exhibit house or agent makes satisfactory arrangements.  
 Both firms must complete this form and return to GES by the Discount Price Deadline Date. It is understood and agreed that the exhibitor (exhibiting company) is ultimately responsible for payment of charges. If the named third party has paid any outstanding invoices before the last day of the show, any and all outstanding balances will be charged to the exhibiting company's credit card.

**Exhibiting Company**

Name of Exhibiting Company \_\_\_\_\_ Phone# \_\_\_\_\_ Fax # \_\_\_\_\_  
 Address \_\_\_\_\_ City \_\_\_\_\_ Prov / State \_\_\_\_\_ Code / Zip \_\_\_\_\_  
 Authorized Name (Print) \_\_\_\_\_ Authorized Signature \_\_\_\_\_

**CREDIT CARD AUTHORIZATION**

VISA  AMERICAN EXPRESS  MASTERCARD EXPIRY DATE: \_\_\_\_\_  
 TYPE OF CARD  PERSONAL  CORPORATE  
 CARD #

CARDHOLDER'S NAME (PRINT): \_\_\_\_\_

CARDHOLDER'S SIGNATURE: \_\_\_\_\_

**Third Party / Exhibit House**

Name of Third Party / Exhibit House \_\_\_\_\_ Phone# \_\_\_\_\_ Fax # \_\_\_\_\_  
 Address \_\_\_\_\_ City \_\_\_\_\_ Prov / State \_\_\_\_\_ Code / Zip \_\_\_\_\_  
 Authorized Name (Print) \_\_\_\_\_ Authorized Signature \_\_\_\_\_

**CREDIT CARD AUTHORIZATION**

VISA  AMERICAN EXPRESS  MASTERCARD EXPIRY DATE: \_\_\_\_\_  
 TYPE OF CARD  PERSONAL  CORPORATE  
 CARD #

CARDHOLDER'S NAME (PRINT): \_\_\_\_\_

CARDHOLDER'S SIGNATURE: \_\_\_\_\_

**ALL GES SERVICES ARE TO BE CHARGED TO THE THIRD PARTY / EXHIBIT HOUSE EXCEPT FOR THE FOLLOWING:**

**PLEASE SEE NOTE REGARDING GES TERMS AND CONDITIONS BELOW**

All equipment rental orders placed with GES are bound by the terms and conditions specific to each rental order form, material handling terms and conditions and GES standard terms and conditions located at the back of this kit. By signing below, you agree to all these terms and conditions. Without an authorized signature and date below, your order will not be processed.

I HAVE READ AND UNDERSTAND THE TERMS & CONDITIONS OF MY AGREEMENT WITH GES.

Signature \_\_\_\_\_ Print Name & Title \_\_\_\_\_ Date \_\_\_\_\_

SHOW NAME:

**VRIC 2014**

DISCOUNT PRICE

Friday, January 03, 2014

SHOW DATE:

**January 19-20, 2014**

DEADLINE DATE

Please return confirmation by fax that this wire transfer has been sent to:

**Magda Roithmeier**

**Accounts Receivable**

**GES**

**Phone: 905-283-0574 or**

**Fax: 905-283-0501 or**

**Email: ar@ges.com**

Your Company Name: \_\_\_\_\_

Contact Name: \_\_\_\_\_

Contact Number: \_\_\_\_\_

Booth Number: \_\_\_\_\_

Event Name: \_\_\_\_\_

### GES BANK INFORMATION

#### If you are sending Canadian Dollars

PLEASE INCLUDE ALL THE FOLLOWING INFORMATION TO ENSURE YOUR FUNDS REACH OUR BANK

**Account Name:** GES Exposition Services (Canada) Limited

**Bank Name:** Canadian Imperial Bank of Commerce

**Address:** 939 Lawrence Avenue E.

North York, Ontario Canada

M2C 1P9

**Swift Code:** CIBCCATT

**Account #:** 73-07616

**Beneficiary's Bank:** //CC001000132

**Routing / BIC / NCC/ BSC or ABA Number:** 026009593

**Invoice Amount:** \_\_\_\_\_ **Date of Transfer:** \_\_\_\_\_

**Min. Bank Charge:** \$20.00 (North American / \$40.00 (International))

**Total:** \_\_\_\_\_

#### If you are sending American Dollars

PLEASE INCLUDE ALL THE FOLLOWING INFORMATION TO ENSURE YOUR FUNDS REACH OUR BANK

**Account Name:** GES Exposition Services (Canada) Limited

**Bank Name:** Canadian Imperial Bank of Commerce

**Address:** 939 Lawrence Avenue E.

North York, Ontario Canada

M2C 1P9

**Swift Code:** CIBCCATT

**Account #:** 0267015

**Beneficiary's Bank:** //CC001000132

**Routing / BIC / NCC/ BSC or ABA Number:** 026009593

**Invoice Amount:** \_\_\_\_\_ **Date of Transfer:** \_\_\_\_\_

**Min. Bank Charge:** \$20.00 (North American / \$40.00 (International))

**Total:** \_\_\_\_\_

**Please Note:** Ensure transfer is made a minimum of 10 days prior to the show move in date.  
\*Minimum Bank Charges as shown above, reflect GES's bank charges only.  
Any additional Wire Transfer and EFT fees are the exhibitors responsibility.





# furnishings

Grey Fabric Side Chair



Grey Fabric Counter Stool



Grey Fabric Arm Chair



Steno Chair



30" Round / 30" High Pedestal Table



30" Round / 18" High Coffee Table



4', 6', OR 8' Long Raised Draped Table with White Vinyl Top



4', 6', OR 8' Long Draped Table with White Vinyl Top



# furnishings



Coat Tree



22" X 28"  
Chrome Sign Holder  
(sign extra)



Easel



Gold Ballot Drum



Plexi Pocket



40" w x 20" d x 36" h  
White Counter Storage Unit



Bag Holder 41"H



Stanchions



Plastic  
Wastebasket



# FURNISHINGS ORDER FORM

SHOW NAME: **VRIC 2014**  
 SHOW DATE: **January 19-20, 2014**

DISCOUNT PRICE DEADLINE DATE: **Friday, January 03, 2014**

**EXHIBITOR INFORMATION**

BOOTH #: \_\_\_\_\_

COMPANY: \_\_\_\_\_

STREET: \_\_\_\_\_

CITY: \_\_\_\_\_ PROV/STATE: \_\_\_\_\_ CODE: \_\_\_\_\_

EMAIL: \_\_\_\_\_

PHONE: \_\_\_\_\_ FAX: \_\_\_\_\_

CONTACT NAME: \_\_\_\_\_

**CREDIT CARD AUTHORIZATION**

NO ORDER WILL BE CONSIDERED FINAL UNTIL CREDIT CARD AUTHORIZATION FORM IS COMPLETED AND SUBMITTED WITH THIS FORM.

**ALL ORDERS MUST BE PREPAID IN FULL (ORDERS CANNOT BE PROCESSED UNTIL PAYMENT IS RECEIVED)**

FURNISHINGS					SKIRTED TABLES 30" HIGH				
QTY	DESCRIPTION	DISCOUNT PRICE	REGULAR PRICE	TOTAL	<input type="checkbox"/> BLACK <input type="checkbox"/> BLUE <input type="checkbox"/> SILVER <input type="checkbox"/> WHITE <input type="checkbox"/> RED <input type="checkbox"/> GREEN <input type="checkbox"/> BURGUNDY				
QTY	DESCRIPTION	DISCOUNT PRICE	REGULAR PRICE	TOTAL	QTY	DESCRIPTION	DISCOUNT PRICE	REGULAR PRICE	TOTAL
	GREY FABRIC SIDE CHAIR	\$50.00	\$70.00			4 FT LONG X 2 FT WIDE	\$99.00	\$138.00	
	GREY FABRIC COUNTER STOOL	\$104.00	\$156.00			6 FT LONG X 2 FT WIDE	\$99.00	\$138.00	
	GREY FABRIC ARM CHAIR	\$68.00	\$95.00			8 FT LONG X 2 FT WIDE	\$99.00	\$138.00	
	STENO CHAIR C/W ARMS	\$88.00	\$124.00			SKIRTED FOURTH SIDE	\$33.00	\$47.00	
	COFFEE TABLE 18" HIGH ROUND	\$81.00	\$114.00			<b>SKIRTED COUNTER 42" HIGH</b>			
	STARBASE TABLE 30" ROUND 30" HIGH	\$87.00	\$122.00			<input type="checkbox"/> BLACK <input type="checkbox"/> BLUE <input type="checkbox"/> SILVER <input type="checkbox"/> WHITE			
	COCKTAIL TABLE 30" ROUND 40" HIGH	\$97.00	\$145.00		QTY	DESCRIPTION	DISCOUNT PRICE	REGULAR PRICE	TOTAL
	COAT TREE	\$50.00	\$70.00			4 FT LONG X 2 FT WIDE	\$119.00	\$166.00	
	22" X 28" CHROME SIGN HOLDER (SIGN EXTRA)	\$70.00	\$98.00			6 FT LONG X 2 FT WIDE	\$130.00	\$182.00	
	EASEL	\$44.00	\$61.00			8 FT LONG X 2 FT WIDE	\$141.00	\$198.00	
	SMALL GOLD BALLOT DRUM	\$71.00	\$99.00			SKIRTED FOURTH SIDE	\$33.00	\$47.00	
	WHITE COUNTER STORAGE 40" HIGH	\$182.00	\$255.00		<b>NON SKIRTED 30" HIGH TABLES (VINYL ONLY)</b>				
	BAG HOLDER 40" HIGH	\$62.00	\$87.00			<input type="checkbox"/> 4FT <input type="checkbox"/> 6FT <input type="checkbox"/> 8FT	\$60.00	\$84.00	
	1 PAIR OF STANCHIONS	\$60.00	\$84.00		<b>NON SKIRTED 42" HIGH TABLES (VINYL ONLY)</b>				
	ADDITIONAL STANCHIONS	\$30.00	\$42.00			<input type="checkbox"/> 4FT <input type="checkbox"/> 6FT <input type="checkbox"/> 8FT	\$86.00	\$121.00	
	DISPOSABLE WASTE BASKET	\$21.00	\$29.00		<b>CUSTOM BOOTH DRAPING</b>				
	BASEPLATE & 8 FT H POLE	\$17.00	\$23.00			<input type="checkbox"/> BLACK <input type="checkbox"/> BLUE <input type="checkbox"/> WHITE <input type="checkbox"/> RED <input type="checkbox"/> GREEN			
	6FT - 10 FT CROSSBAR	\$13.00	\$17.00		QTY	DESCRIPTION	DISCOUNT PRICE	REGULAR PRICE	TOTAL
	CLIPROD	\$11.00	\$15.00			3' HIGH (PER LINEAR FOOT)	\$13.00	\$17.00	
						8' HIGH (PER LINEAR FOOT)	\$16.00	\$22.00	

**TERMS AND CONDITIONS**

- ALL ORDERS RECEIVED AFTER DISCOUNT PRICE DATE WILL BE PROCESSED AT THE REGULAR PRICE.
- EXHIBITOR IS RESPONSIBLE FOR ALL ITEMS FOR THE DURATION OF THE SHOW.
- IF A COLOUR IS NOT CHOSEN, GES WILL CHOOSE A COLOUR FOR YOU.
- CHARGES ARE FOR RENTAL OF EQUIPMENT ONLY. ALL ITEMS REMAIN THE PROPERTY OF GES.
- GES IS NOT RESPONSIBLE FOR EXHIBIT MATERIALS LEFT IN GEM RENTAL EXHIBITS OR COUNTER STORAGE UNITS.
- ALL CLAIMS OR DISCREPANCIES MUST BE SETTLED AT THE GES SERVICE CENTRE PRIOR TO SHOW CLOSING.
- NO REFUNDS/EXCHANGES ON CANCELLED SKIRTED TABLES OR CUSTOM BOOTH DRAPING ONCE DELIVERED.
- 50% REFUND ON FURNISHINGS CANCELLED PRIOR TO SHOW OPENING EXCEPT AS NOTED ABOVE.

I HAVE READ AND UNDERSTAND THE TERMS & CONDITIONS OF MY AGREEMENT WITH GES.

<b>SUBTOTAL</b>	
<b>GST 5%</b>	
<b>PST 7%</b>	
<b>TOTAL</b>	
<b>INCLUDE TOTAL FROM THIS PAGE ON ORDER CHECKLIST SHEET</b>	

SIGNATURE

DATE

# specialty furniture



Black Ladder Stool



Equino White Stool

Wire Back Chrome Stool



Black Leather Stool

Black Zebrano Stool



Black Corbusier  
Leather Chair



Black Corbusier  
Leather Loveseat

24" Square Chrome/White  
Cocktail Table



30" Round Cocktail Table  
Black Top

30" Square Cocktail Table  
Black Top



White Sculpted  
Leather Chair



White Sculpted  
Leather Loveseat

Black Leather Square Back  
Tub Chair





# specialty furniture



42" Round  
Black Meeting Table



Grey Leather Ripple  
Sled Base Meeting Chair



Black Leather Ripple  
Sled Base Meeting Chair



Bar Fridge



Literature  
Stand



Mahogany Coffee Table



Mahogany End Table



24" Round End Table  
White Top



24" Round End Table  
Black Top



32" Round Coffee Table  
Black Top



39" Round Coffee Table  
Black Top



32" Round Coffee Table  
White Top



39" Round Coffee Table  
White Top



Unit 4 - 7978 N. Fraser Way Burnaby, BC V5J 0C7 Phone: 778.452.6220 Fax: 778.452.6221 Toll Free: 855.526.7182 vancouvercustomerservice@ges.com

<b>SHOW NAME:</b>	<b>VRIC 2014</b>	<b>DISCOUNT PRICE DEADLINE DATE:</b>	Friday, January 03, 2014
<b>SHOW DATE:</b>	<b>January 19-20, 2014</b>		

EXHIBITOR INFORMATION	CREDIT CARD AUTHORIZATION
<p><b>BOOTH #:</b> _____</p> <p>COMPANY: _____</p> <p>STREET: _____</p> <p>CITY: _____ PROV/STATE: _____ CODE: _____</p> <p>EMAIL: _____</p> <p>PHONE: _____ FAX: _____</p> <p>CONTACT NAME: _____</p>	<p><b>NO ORDER WILL BE CONSIDERED FINAL UNTIL CREDIT CARD AUTHORIZATION FORM IS COMPLETED AND SUBMITTED WITH THIS FORM</b></p>

**ALL ORDERS MUST BE PREPAID IN FULL  
(ORDERS CANNOT BE PROCESSED UNTIL PAYMENT IS RECEIVED)**

QTY	DESCRIPTION	DISCOUNT PRICE	REGULAR PRICE	TOTAL
	BLACK LADDER STOOL (CLOTH SEAT)	\$149.00	\$208.00	
	BLACK LADDER STOOL	\$149.00	\$208.00	
	EQUINO WHITE STOOL	\$149.00	\$208.00	
	WIRE BACK CHROME STOOL	\$156.00	\$218.00	
	BLACK DIAMOND BACK STOOL	\$156.00	\$218.00	
	BLACK CORBUSIER LEATHER CHAIR	\$253.00	\$354.00	
	BLACK CORBUSIER LEATHER LOVESEAT	\$331.00	\$463.00	
	WHITE SCULPED LEATHER CHAIR	\$218.00	\$306.00	
	WHITE SCULPED LEATHER LOVESEAT	\$291.00	\$408.00	
	BLACK LEATHER SQ. BACK TUB CHAIR	\$213.00	\$298.00	
	WHITE LEATHER SQ. BACK TUB CHAIR	\$213.00	\$298.00	
	BLACK LEATHER RND. BACK TUB CHAIR	\$198.00	\$277.00	
	WHITE LEATHER RND. BACK TUB CHAIR	\$198.00	\$277.00	
	BLACK RIPPLE SLED BASE MEETING CHAIR	\$218.00	\$306.00	

QTY	DESCRIPTION	DISCOUNT PRICE	REGULAR PRICE	TOTAL
	CHROME/WHITE COCKTAIL TABLE (24" SQUARE TOP, 42" HIGH)	\$149.00	\$223.00	
	ROUND CRUISER TABLE (BLACK 30" DIA, 42" HIGH)	\$139.00	\$209.00	
	42" BLACK MEETING TABLE (ROUND)	\$138.00	\$194.00	
	BLACK ROUND COFFEE TABLE (32" DIAMETER)	\$131.00	\$183.00	
	BLACK ROUND COFFEE TABLE (39" DIAMETER)	\$131.00	\$183.00	
	WHITE ROUND COFFEE TABLE (32" DIAMETER)	\$115.00	\$162.00	
	BLACK ROUND END TABLE (24" DIAMETER)	\$115.00	\$162.00	
	WHITE ROUND END TABLE (24" DIAMETER)	\$115.00	\$162.00	
	MAHOGANY COFFEE TABLE (24" X 48")	\$125.00	\$175.00	
	MAHOGANY END TABLE (24" X 24")	\$108.00	\$151.00	
	LITERATURE STAND - SINGLE SIDED	\$78.00	\$109.00	
	LITERATURE STAND - DOUBLE SIDED	\$166.00	\$233.00	
	BAR FRIDGE	\$184.00	\$258.00	
<b>NOTE - 3 SEATER SOFA AVAILABLE UPON REQUEST</b>				

**TERMS AND CONDITIONS**

- ALL ORDERS RECEIVED AFTER DISCOUNT PRICE DATE WILL BE PROCESSED AT THE REGULAR PRICE.
- EXHIBITOR IS RESPONSIBLE FOR ALL ITEMS FOR THE DURATION OF THE SHOW.
- IF A COLOUR IS NOT CHOSEN, GES WILL CHOOSE A COLOUR FOR YOU.
- CHARGES ARE FOR RENTAL OF EQUIPMENT ONLY. ALL ITEMS REMAIN THE PROPERTY OF GES.
- GES IS NOT RESPONSIBLE FOR EXHIBIT MATERIALS LEFT IN GEM RENTAL EXHIBITS OR COUNTER STORAGE UNITS.
- ALL CLAIMS OR DISCREPANCIES MUST BE SETTLED AT THE GES SERVICE CENTRE PRIOR TO SHOW CLOSING.
- NO REFUNDS/EXCHANGES ON CANCELLED SKIRTED TABLES OR CUSOM BOOTH DRAPING ONCE DELIVERED.
- 50% REFUND ON FURNISHINGS CANCELLED PRIOR TO SHOW OPENING EXCEPT AS NOTED ABOVE.

I HAVE READ AND UNDERSTAND THE TERMS & CONDITIONS OF MY AGREEMENT WITH GES.

<b>SUBTOTAL</b>	
<b>GST 5%</b>	
<b>PST 7%</b>	
<b>TOTAL</b>	
<b>INCLUDE TOTAL FROM THIS PAGE ON ORDER CHECKLIST SHEET</b>	

\_\_\_\_\_  
SIGNATURE

\_\_\_\_\_  
DATE

**SHOW NAME:** **VRIC 2014**  
**SHOW DATE:** **January 19-20, 2014**

**DISCOUNT PRICE DEADLINE DATE:** Friday, January 03, 2014

**EXHIBITOR INFORMATION**

**CREDIT CARD AUTHORIZATION**

**BOOTH #:** \_\_\_\_\_  
**COMPANY:** \_\_\_\_\_  
**STREET:** \_\_\_\_\_  
**CITY:** \_\_\_\_\_ **PROV/STATE:** \_\_\_\_\_ **CODE:** \_\_\_\_\_  
**EMAIL:** \_\_\_\_\_  
**PHONE:** \_\_\_\_\_ **FAX:** \_\_\_\_\_  
**CONTACT NAME:** \_\_\_\_\_

**NO ORDER WILL BE CONSIDERED FINAL UNTIL CREDIT CARD AUTHORIZATION FORM IS COMPLETED AND SUBMITTED WITH THIS FORM.**

**ALL ORDERS MUST BE PREPAID IN FULL**

**(ORDERS CANNOT BE PROCESSED UNTIL PAYMENT IS RECEIVED)**

**BOOTH CARPET - STANDARD SIZE**

*NOTE: EXHIBITORS ORDERING MULTIPLE PIECES OF CARPET IN THIS SECTION MAY NOT RECEIVE THE SAME DYELOT*

QTY.	DESCRIPTION	DISCOUNT PRICE	REGULAR PRICE	TOTAL
	10 X 10 SINGLE BOOTH	\$178.00	\$249.00	
	10 X 20 DOUBLE BOOTH	\$356.00	\$498.00	
	10 X 30 INLINE BOOTH (STRAIGHT LINE)	\$534.00	\$747.00	
<b>COLOUR SELECTION:</b> <input type="checkbox"/> BLACK <input type="checkbox"/> BLUE <input type="checkbox"/> GREY <input type="checkbox"/> RED <input type="checkbox"/> GREEN				

**BOOTH CARPET - CUSTOM SIZE**

*IF YOUR BOOTH REQUIRES A SIZE NOT LISTED ABOVE, PLEASE COMPLETE THIS SECTION.*

<b>BOOTH SIZE:</b> _____ FT. X _____ FT. = _____ SQ. FT.	\$2.33	\$3.26	
<b>COLOUR SELECTION:</b> <input type="checkbox"/> BLACK <input type="checkbox"/> BLUE <input type="checkbox"/> GREY <input type="checkbox"/> RED <input type="checkbox"/> GREEN			

**UNDERPADDING - PRICE PER SQUARE FOOT INSTALLED (100 SQ. FT. MIN.)**

<b>BOOTH SIZE:</b> _____ FT. X _____ FT. = _____ SQ. FT.	\$1.20	\$1.67	
--	--------	--------	--

**PROTECTIVE PLASTIC COVERING - PRICE PER SQ. FT. INSTALLED (STANDARD SIZES ONLY) - PRICING IS FOR INSTALLATION ONLY. EXHIBITOR IS RESPONSIBLE FOR REMOVAL.**

<b>BOOTH SIZE:</b> _____ FT. X _____ FT. = _____ SQ. FT.	\$0.99	\$1.38	
--	--------	--------	--

**PLEASE SELECT ONE FOR STANDARD OR CUSTOM SIZE CARPETS**

IF ORDERING ELECTRICAL OR TELECOMMUNICATIONS SERVICES, WILL UNDER CARPET WIRING BE REQUIRED?

YES    NO

**TERMS AND CONDITIONS**

- ALL ORDERS RECEIVED AFTER DISCOUNT PRICE DATE WILL BE PROCESSED AT THE REGULAR PRICE.
- EXHIBITOR IS RESPONSIBLE FOR ALL ITEMS FOR THE DURATION OF THE SHOW.
- NO REFUNDS/EXCHANGES ON CARPETS ONCE DELIVERED.
- CHARGES ARE FOR RENTAL OF EQUIPMENT ONLY. ALL ITEMS REMAIN THE PROPERTY OF GES.
- ALL CLAIMS OR DISCREPANCIES MUST BE SETTLED AT THE GES SERVICE CENTRE PRIOR TO SHOW CLOSING.
- IF A COLOUR IS NOT CHOSEN, GES WILL CHOOSE A COLOUR FOR YOU. CARPET COLOUR SUBJECT TO AVAILABILITY

<b>SUBTOTAL</b>	
<b>GST 5%</b>	
<b>PST 7%</b>	
<b>TOTAL</b>	

**INCLUDE TOTAL FROM THIS PAGE ON ORDER CHECKLIST SHEET**

I HAVE READ AND UNDERSTAND THE TERMS & CONDITIONS OF MY AGREEMENT WITH GES.

\_\_\_\_\_  
SIGNATURE

\_\_\_\_\_  
DATE



Unit 4 - 7978 N. Fraser Way Burnaby, BC V5J 0C7 Phone: 778.452.6220 Fax: 778.452.6221 Toll Free: 855.526.7182 vancouvercustomerservice@ges.com

**SHOW NAME:** VRIC 2014  
**SHOW DATE:** January 19-20, 2014

**DISCOUNT PRICE DEADLINE DATE:** Friday, January 03, 2014

**EXHIBITOR INFORMATION**

**CREDIT CARD AUTHORIZATION**

**BOOTH #:** \_\_\_\_\_  
**COMPANY:** \_\_\_\_\_  
**STREET:** \_\_\_\_\_  
**CITY:** \_\_\_\_\_ **PROV/STATE:** \_\_\_\_\_ **CODE:** \_\_\_\_\_  
**EMAIL:** \_\_\_\_\_  
**PHONE:** \_\_\_\_\_ **FAX:** \_\_\_\_\_  
**CONTACT NAME:** \_\_\_\_\_

**NO ORDER WILL BE CONSIDERED FINAL UNTIL CREDIT CARD AUTHORIZATION FORM IS COMPLETED AND SUBMITTED WITH THIS FORM**

**ALL ORDERS MUST BE PREPAID IN FULL (ORDERS CANNOT BE PROCESSED UNTIL PAYMENT IS RECEIVED)**

## Create a Lasting Impression!



GREEN FLOOR PLANTS				
QTY	DESCRIPTION	DISCOUNT	REGULAR	TOTAL
	2 FT. TO 5 FT. TALL	\$58.00	\$82.00	
	6 FT. TO 8 FT. TALL	\$97.00	\$135.00	
	9 FT. TO 10 FT. TALL (Indoor Tree)	CALL FOR QUOTE		
GREEN TABLE PLANTS				
	BOSTON FERN	\$50.00	\$70.00	
	TABLE PLANT - 10"	\$46.00	\$64.00	
	MUMS	\$33.00	\$47.00	
FLOWERING PLANTS & SPECIAL REQUESTS				
	STANDARD FRESH FLOWERS	CALL FOR QUOTE		
	PREMIUM FRESH FLOWERS			
	EXOTIC ARRANGEMENT			



PLEASE NOTE: Prices for flowering plants may change depending on type of flowers requested. Please List below the types of flowers you require along with any specific instructions and our Exhibitor Service Department will check on availability and price. If nothing listed, GES will provide an arrangement based on show location and time of year.

**TERMS AND CONDITIONS**

ALL ORDERS RECEIVED AFTER DISCOUNT PRICE DATE WILL BE PROCESSED AT THE REGULAR PRICE.  
 EXHIBITOR IS RESPONSIBLE FOR ALL ITEMS FOR THE DURATION OF THE SHOW. NO REFUNDS, EXCHANGES OR CANCELLATIONS ON SITE.  
 CHARGES ARE FOR RENTAL OF EQUIPMENT ONLY. ALL ITEMS REMAIN THE PROPERTY OF GES.  
 ALL CLAIMS OR DISCREPANCIES MUST BE SETTLED AT THE GES SERVICE CENTRE PRIOR TO SHOW CLOSING.

<b>SUBTOTAL</b>	
<b>GST 5%</b>	
<b>PST 7%</b>	
<b>TOTAL</b>	
<b>INCLUDE TOTAL FROM THIS PAGE ON ORDER CHECKLIST SHEET</b>	

I HAVE READ AND UNDERSTAND THE TERMS & CONDITIONS OF MY AGREEMENT WITH GES.

\_\_\_\_\_  
SIGNATURE

\_\_\_\_\_  
DATE



# standard exhibit rentals

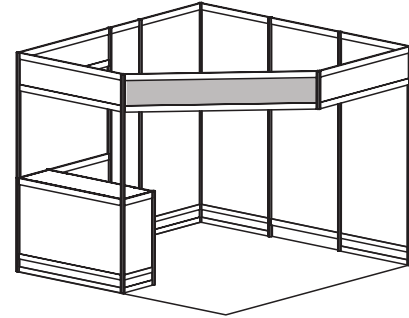

■ GEM Model #1 - 10'x10' Corner

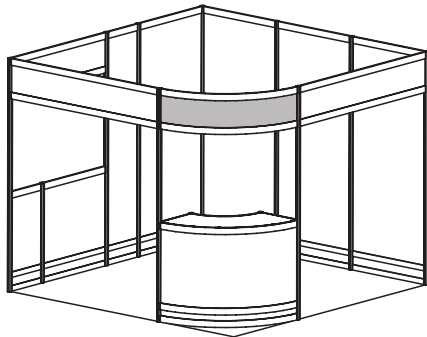

■ GEM Model #2 - 10'x10' Corner

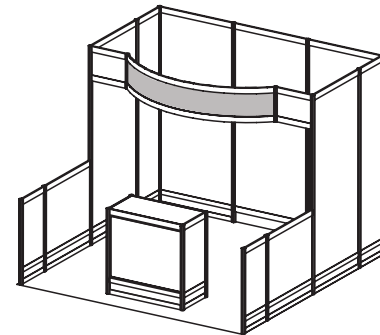

■ GEM Model #3 - 10'x10'

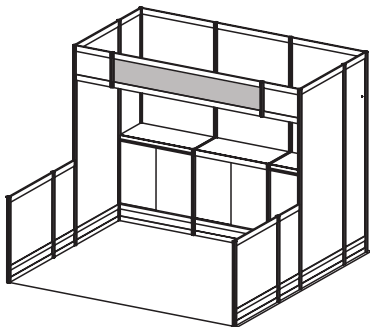

■ GEM Model #4 - 10'x10'

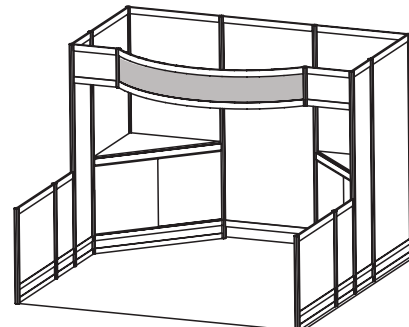

■ GEM Model #5 - 10'x10'

## 3 Easy Steps →

- 1 Select the model number that suits your needs
- 2 Choose carpet and panel colours on the GEM Exhibit Rental order form
- 3 Complete & send order form

Grey indicates standard header sign(s)



# standard exhibit rentals

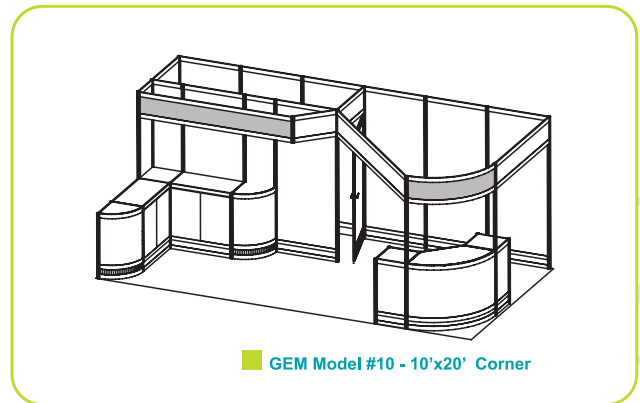
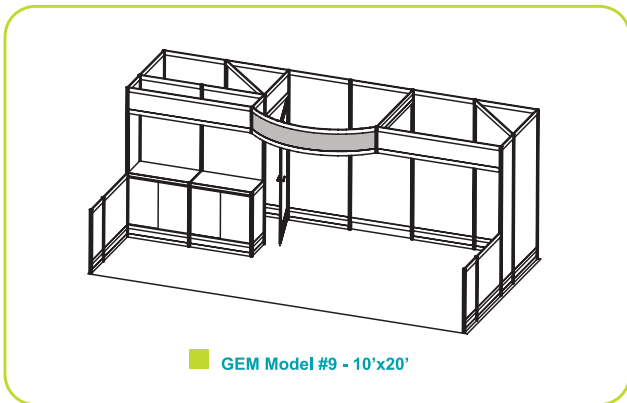
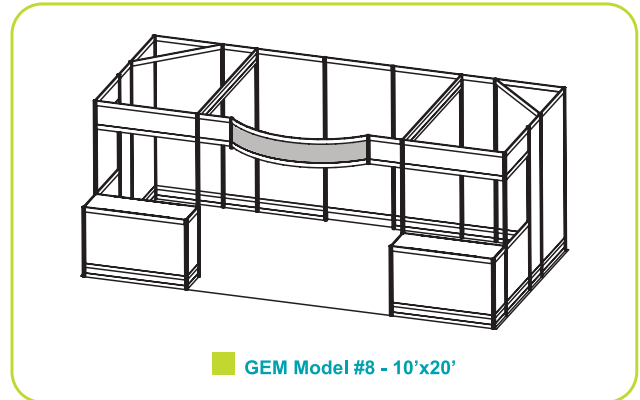
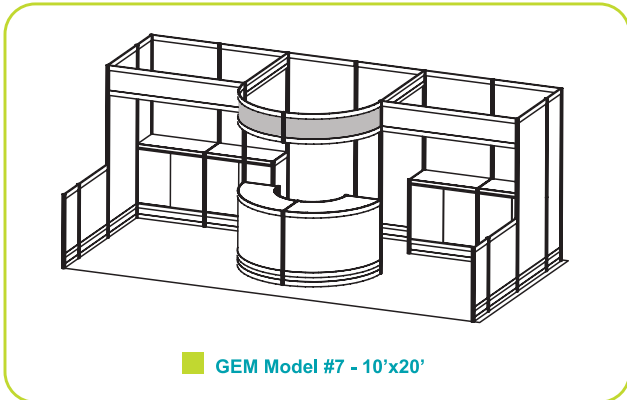
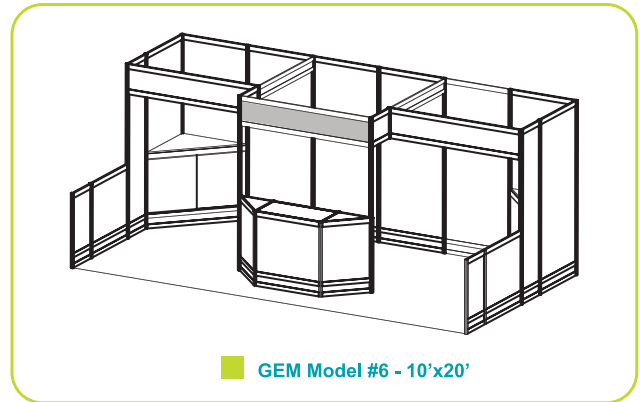

## 3 Easy Steps →

- 1 Select the model number that suits your needs
- 2 Choose carpet and panel colours on the GEM Exhibit Rental order form
- 3 Complete & send order form

Grey indicates standard header sign(s)

Unit 4 - 7978 N. Fraser Way Burnaby, BC V5J 0C7 Phone: 778.452.6220 Fax: 778.452.6221 Toll Free: 855.526.7182 vancouvercustomerservice@ges.com

<b>SHOW NAME:</b>	<b>VRIC 2014</b>	<b>DISCOUNT PRICE DEADLINE DATE:</b>	Friday, January 03, 2014
<b>SHOW DATE:</b>	<b>January 19-20, 2014</b>		

EXHIBITOR INFORMATION	CREDIT CARD AUTHORIZATION
<p><b>BOOTH #:</b> _____</p> <p>COMPANY: _____</p> <p>STREET: _____</p> <p>CITY: _____ PROV/STATE: _____ CODE: _____</p> <p>EMAIL: _____</p> <p>PHONE: _____ FAX: _____</p> <p>CONTACT NAME: _____</p>	<p><b>NO ORDER WILL BE CONSIDERED FINAL UNTIL CREDIT CARD AUTHORIZATION FORM IS COMPLETED AND SUBMITTED WITH THIS FORM</b></p>

**ALL ORDERS MUST BE PREPAID IN FULL (ORDERS CANNOT BE PROCESSED UNTIL PAYMENT IS RECEIVED)**

## SHOW SPECIAL !

➔ SPEND LESS
➔ SELL MORE
➔ LOOK GREAT

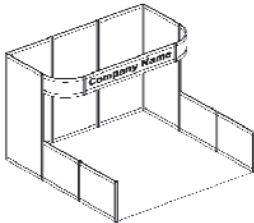
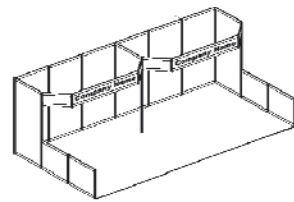
	<p><b>INSTALLED &amp; DISMANTLED READY BEFORE YOU ARRIVE</b></p> <p><b>NO LABOUR COSTS</b></p> <p><b>NO TRUCKING COSTS</b></p> <p><b>NO MATERIAL HANDLING COSTS</b></p> <p><b>INCLUDES CARPET</b></p> <p><b>INCLUDES HEADER SIGN(S)</b></p> <p><b>CHOICE OF LIMITED COLOURS</b></p> <p><b>ACCESSORIES AVAILABLE</b></p>																									
<table border="1" style="width: 100%; border-collapse: collapse;"> <tr> <td><b>DISCOUNT PRICE</b></td> <td style="text-align: right;">\$962.00</td> </tr> <tr> <td colspan="2"><b>PACKAGE A: 10' X 10' BOOTH INCLUDES:</b></td> </tr> <tr> <td colspan="2">- HEADER SIGN 11½" X 77½"</td> </tr> <tr> <td colspan="2">- INFILL PANELS - SELECT COLOUR BELOW</td> </tr> <tr> <td colspan="2">- COLOR COORDINATED 10' X 10' CARPET</td> </tr> <tr> <td><b>REGULAR PRICE</b></td> <td style="text-align: right;">\$1,443.00</td> </tr> </table>	<b>DISCOUNT PRICE</b>	\$962.00	<b>PACKAGE A: 10' X 10' BOOTH INCLUDES:</b>		- HEADER SIGN 11½" X 77½"		- INFILL PANELS - SELECT COLOUR BELOW		- COLOR COORDINATED 10' X 10' CARPET		<b>REGULAR PRICE</b>	\$1,443.00		<table border="1" style="width: 100%; border-collapse: collapse;"> <tr> <td><b>DISCOUNT PRICE</b></td> <td style="text-align: right;">\$1,508.00</td> </tr> <tr> <td colspan="2"><b>PACKAGE B: 10' X 20' BOOTH INCLUDES:</b></td> </tr> <tr> <td colspan="2">- 2 HEADER SIGNS 11½" X 77½"</td> </tr> <tr> <td colspan="2">- INFILL PANELS - SELECT COLOUR BELOW</td> </tr> <tr> <td colspan="2">- COLOR COORDINATED 10' X 10' CARPET</td> </tr> <tr> <td><b>REGULAR PRICE</b></td> <td style="text-align: right;">\$2,262.00</td> </tr> </table>	<b>DISCOUNT PRICE</b>	\$1,508.00	<b>PACKAGE B: 10' X 20' BOOTH INCLUDES:</b>		- 2 HEADER SIGNS 11½" X 77½"		- INFILL PANELS - SELECT COLOUR BELOW		- COLOR COORDINATED 10' X 10' CARPET		<b>REGULAR PRICE</b>	\$2,262.00
<b>DISCOUNT PRICE</b>	\$962.00																									
<b>PACKAGE A: 10' X 10' BOOTH INCLUDES:</b>																										
- HEADER SIGN 11½" X 77½"																										
- INFILL PANELS - SELECT COLOUR BELOW																										
- COLOR COORDINATED 10' X 10' CARPET																										
<b>REGULAR PRICE</b>	\$1,443.00																									
<b>DISCOUNT PRICE</b>	\$1,508.00																									
<b>PACKAGE B: 10' X 20' BOOTH INCLUDES:</b>																										
- 2 HEADER SIGNS 11½" X 77½"																										
- INFILL PANELS - SELECT COLOUR BELOW																										
- COLOR COORDINATED 10' X 10' CARPET																										
<b>REGULAR PRICE</b>	\$2,262.00																									

INDICATE DATE AND TIME YOU PLAN TO ARRIVE TO MERCHANDISE YOUR EXHIBIT \_\_\_\_\_ DATE \_\_\_\_\_ TIME \_\_\_\_\_

**PLEASE COMPLETE THE FOLLOWING:**

SIZE ORDERED:	<input type="checkbox"/> PACKAGE A (10 X 10)	<input type="checkbox"/> PACKAGE B (10 X 20)	
INFILL PANEL COLOUR:	<input type="checkbox"/> BLACK	<input type="checkbox"/> GREY	<input type="checkbox"/> WHITE
CARPET COLOUR:	<input type="checkbox"/> BLACK	<input type="checkbox"/> GREY	

PACKAGE A IDENTIFICATION SIGN TO READ: \_\_\_\_\_

PACKAGE B IDENTIFICATION SIGNS TO READ: LEFT: \_\_\_\_\_ RIGHT: \_\_\_\_\_

CUSTOM HEADER TO BE ADDED **CUSTOM HEADER SIGNS / LOGOS WILL CHARGED \$100.00 EXTRA PER SIGN IF ORDERED AFTER DEADLINE DATE**

**PLEASE UPLOAD GRAPHIC FILES TO: <http://www.gesexpo.ca/upload/vancouver>**

(ALL PANEL & CARPET COLOURS SUBJECT TO AVAILABILITY.)

**TERMS AND CONDITIONS**

- DOES NOT INCLUDE LIGHTING OR ELECTRICAL SERVICE.
- NO REFUNDS/EXCHANGES ONCE SHOW MOVE-IN BEGINS.
- ALL CLAIMS OR DISCREPANCIES MUST BE SETTLED AT THE GES SERVICE CENTRE PRIOR TO SHOW CLOSING.
- ALL ORDERS RECEIVED AFTER DISCOUNT PRICE DATE WILL BE PROCESSED AT THE REGULAR PRICE.
- GES IS NOT RESPONSIBLE FOR EXHIBIT MATERIALS LEFT IN GEM RENTAL EXHIBITS OR COUNTER STORAGE UNITS.
- CHANGES TO THE STRUCTURE DESIGN OR GRAPHICS WILL RESULT IN ADDITIONAL FEES.
- EXHIBITOR IS RESPONSIBLE FOR ALL ITEMS DURING THE DURATION OF THE SHOW.

<b>SUBTOTAL</b>	
<b>GST 5%</b>	
<b>PST 7%</b>	
<b>TOTAL</b>	
<b>INCLUDE TOTAL FROM THIS PAGE ON ORDER CHECKLIST SHEET</b>	

I HAVE READ AND UNDERSTAND THE TERMS & CONDITIONS OF MY AGREEMENT WITH GES

\_\_\_\_\_  
SIGNATURE

\_\_\_\_\_  
DATE

Unit 4 - 7978 N. Fraser Way Burnaby, BC V5J 0C7 Phone: 778.452.6220 Fax: 778.452.6221 Toll Free: 855.526.7182 [vancouvercustomerservice@ges.com](mailto:vancouvercustomerservice@ges.com)

<b>SHOW NAME:</b>	<b>VRIC 2014</b>	<b>DISCOUNT PRICE DEADLINE DATE:</b>	Friday, January 03, 2014
<b>SHOW DATE:</b>	<b>January 19-20, 2014</b>		

EXHIBITOR INFORMATION	CREDIT CARD AUTHORIZATION
<b>BOOTH #:</b> _____  COMPANY: _____  STREET: _____  CITY: _____ PROV/STATE: _____ CODE: _____  EMAIL: _____  PHONE: _____ FAX: _____  CONTACT NAME: _____	<p style="font-size: 1.2em; margin: 0;"><b>NO ORDER WILL BE CONSIDERED FINAL UNTIL CREDIT CARD AUTHORIZATION FORM IS COMPLETED AND SUBMITTED WITH THIS FORM</b></p>

**ALL ORDERS MUST BE PREPAID IN FULL (ORDERS CANNOT BE PROCESSED UNTIL PAYMENT IS RECEIVED)**

MODEL NUMBER	DISCOUNT PRICE	REGULAR PRICE	MODEL NUMBER	DISCOUNT PRICE	REGULAR PRICE
<b>Model #1 - 10x10 Corner</b>	\$1,147.00	\$1,721.00	<b>Model #6 - 10x20 Inline</b>	\$2,189.00	\$3,284.00
<b>Model #2 - 10x10 Corner</b>	\$1,192.00	\$1,788.00	<b>Model #7 - 10x20 Inline</b>	\$2,901.00	\$4,351.00
<b>Model #3 - 10x10 Inline</b>	\$1,314.00	\$1,970.00	<b>Model #8 - 10x20 Inline</b>	\$2,345.00	\$3,518.00
<b>Model #4 - 10x10 Inline</b>	\$1,562.00	\$2,343.00	<b>Model #9 - 10x20 Inline</b>	\$2,686.00	\$4,029.00
<b>Model #5 - 10x10 Inline</b>	\$1,615.00	\$2,423.00	<b>Model 10-10x20 Corner</b>	\$3,257.00	\$4,886.00

**Package Includes : Installation & Dismantling, Choice of Carpet Colour, Choice of Panel Colour, Company Identification Sign**  
**PACKAGE DOES NOT INCLUDE: Cleaning, Light Fixtures or Electrical Outlets**

**PLEASE COMPLETE THE FOLLOWING:**      **Model Number**       *Upgrade options available. Contact Exhibitor Services.*

FONT COLOUR	<input type="checkbox"/>	BLACK	<input type="checkbox"/>	GREY	<input type="checkbox"/>	WHITE
INFILL PANEL COLOUR:	<input type="checkbox"/>	BLACK	<input type="checkbox"/>	GREY	<input type="checkbox"/>	BLUE
CARPET COLOUR:	<input type="checkbox"/>	BLACK	<input type="checkbox"/>	GREY	<input type="checkbox"/>	BLUE

MODELS 1, 2, 3, 4, 5, 6, 8 OR 9 IDENTIFICATION SIGN TO READ: \_\_\_\_\_

MODELS 7 OR 10 IDENTIFICATION SIGN TO READ: LEFT: \_\_\_\_\_ RIGHT: \_\_\_\_\_

INDICATE DATE & TIME FOR ARRIVAL: \_\_\_\_\_

CUSTOM HEADER TO BE ADDED      *CUSTOM HEADER SIGNS/LOGOS WILL BE CHARGED \$100.00 EXTRA PER SIGN IF ORDERED AFTER DEADLINE DATE*

**TERMS AND CONDITIONS**

PAYMENT MAY BE MADE BY CHEQUE UP TO TWO WEEKS PRIOR TO THE 1ST DAY OF MOVE IN.  
 ALL ORDERS RECEIVED AFTER THE DISCOUNT PRICE DATE WILL BE PROCESSED AT THE REGULAR PRICE.  
 EXHIBITOR IS RESPONSIBLE FOR ALL ITEMS FOR THE DURATION OF THE SHOW.  
 CHARGES ARE FOR RENTAL OF EQUIPMENT ONLY. ALL ITEMS REMAIN PROPERTY OF GES.  
 NO REFUNDS/EXCHANGES ONCE SHOW MOVE-IN BEGINS. ALL CLAIMS OR DISCREPANCIES MUST BE SETTLED PRIOR TO SHOW CLOSING.  
 GES IS NOT RESPONSIBLE FOR EXHIBIT MATERIALS LEFT IN GEM RENTAL EXHIBITS OR COUNTER STORAGE UNITS.  
 CHANGES TO THE STRUCTURE DESIGN OR GRAPHICS WILL RESULT IN ADDITIONAL FEES.

<b>SUBTOTAL</b>	
<b>GST 5%</b>	
<b>PST 7%</b>	
<b>TOTAL</b>	
<b>INCLUDE TOTAL FROM THIS PAGE ON ORDER CHECKLIST SHEET</b>	

I HAVE READ AND UNDERSTAND THE TERMS & CONDITIONS OF MY AGREEMENT WITH GES.

\_\_\_\_\_  
SIGNATURE

\_\_\_\_\_  
DATE









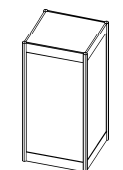
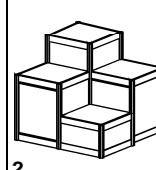
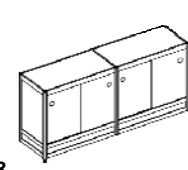
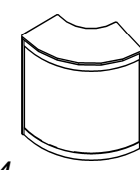

Unit 4 - 7978 N. Fraser Way Burnaby, BC V5J 0C7 Phone: 778.452.6220 Fax: 778.452.6221 Toll Free: 855.526.7182 [vancouvercustomerservice@ges.com](mailto:vancouvercustomerservice@ges.com)

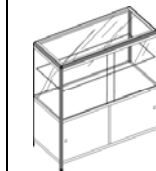
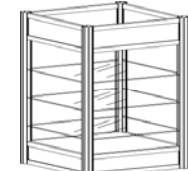
<b>SHOW NAME:</b>	<b>VRIC 2014</b>	<b>DISCOUNT PRICE DEADLINE DATE:</b>	Friday, January 03, 2014
<b>SHOW DATE:</b>	<b>Jan 19-20, 2014</b>		

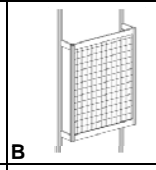
EXHIBITOR INFORMATION	CREDIT CARD AUTHORIZATION
<b>BOOTH #:</b> _____  COMPANY: _____  STREET: _____  CITY: _____ PROV/STATE: _____ CODE: _____  EMAIL: _____  PHONE: _____ FAX: _____  CONTACT NAME: _____	<p style="font-size: 1.2em; margin: 0;"><b>NO ORDER WILL BE CONSIDERED FINAL UNTIL CREDIT CARD AUTHORIZATION FORM IS COMPLETED AND SUBMITTED WITH THIS FORM</b></p>

**ALL ORDERS MUST BE PREPAID IN FULL  
(ORDERS CANNOT BE PROCESSED UNTIL PAYMENT IS RECEIVED)**

QTY	#	DESCRIPTION	DISCOUNT	REGULAR	TOTAL					
	1	Pedestal 20"L x 20"W 28"H OR 36"H	\$88.00	\$133.00						
	2	Pedestal 40"L x 40"W	\$441.00	\$661.00						
	3	Storage Counter 80"L x 20"W x 41"H	\$258.00	\$387.00		1				
	4	Curved Counter 60"L x 20"W x 41"H	\$308.00	\$462.00						
	5	99A Showcase 40"L x 20"W x 41"H	\$284.00	\$426.00						
	6	99B Showcase 40"L x 20"W x 41"H	\$294.00	\$441.00						
	7	99C Showcase 26"L x 26"W x 96"H	\$311.00	\$466.00						
	8	99D Showcase 40"L x 20"W x 96"H	\$386.00	\$579.00						
QTY	#	DESCRIPTION	DISCOUNT	REGULAR	TOTAL					
	A	Waterfall with Eight Balls	\$17.00	\$25.00						
	B	Grid Panels - 38" W x 44"H Panels	\$121.00	\$181.00						
	C	Garment Rail 39"W	\$31.00	\$47.00						
	D	Shelves, Flat or Angled 37"L x 12"W	\$48.00	\$72.00						
	E	Slatwall Panels - 37"W x 96"H Black	\$136.00	\$204.00				<b>ALL UNITS INCLUDE WHITE PANELS</b> Accessories A to E are designed to fit GES Hardwall only		
ADDITIONAL ITEMS NOTE SHOWN										
		Showcase Light	\$73.00	\$109.00			<b>Please attach diagram of booth indicating locations for grid panels and/or slatwall. Grid panels CANNOT be installed in corners.</b>			
		Showcase Lock	\$5.20	\$7.80						

**TERMS AND CONDITIONS**

- DOES NOT INCLUDE LIGHTING OR ELECTRICAL SERVICE.
- NO REFUNDS/EXCHANGES ONCE SHOW MOVE-IN BEGINS.
- ALL CLAIMS OR DISCREPANCIES MUST BE SETTLED AT THE GES SERVICE CENTRE PRIOR TO SHOW CLOSING.
- ALL ORDERS RECEIVED AFTER DISCOUNT PRICE DATE WILL BE PROCESSED AT THE REGULAR PRICE.
- GES IS NOT RESPONSIBLE FOR EXHIBIT MATERIALS LEFT IN GEM RENTAL EXHIBITS OR COUNTER STORAGE UNITS.
- CHANGES TO THE STRUCTURE DESIGN OR GRAPHICS WILL RESULT IN ADDITIONAL FEES.
- EXHIBITOR IS RESPONSIBLE FOR ALL ITEMS DURING THE DURATION OF THE SHOW.

I HAVE READ AND UNDERSTAND THE TERMS & CONDITIONS OF MY AGREEMENT WITH GES.

<b>SUBTOTAL</b>	
<b>GST 5%</b>	
<b>PST 7%</b>	
<b>TOTAL</b>	
<b>INCLUDE TOTAL FROM THIS PAGE ON ORDER CHECKLIST SHEET</b>	

\_\_\_\_\_  
SIGNATURE

\_\_\_\_\_  
DATE

## Accepted File Formats:

**PDF:** High Resolution. Save as “PDF /X-1a”

**Vector Files:** EPS, .AI (Adobe Illustrator CS6 or earlier)

**Bitmaps:** TIF, JPG, BMP, PSD (Adobe Photoshop CS6 or earlier)

## Important Notes:

Bitmap resolution should be no less than 75 ppi (dpi) @ 100% intended output size. Larger than 150 ppi (dpi) @ 100% intended output size is overkill and will only slow production. Please bleed artwork 0.5” top, bottom & sides. If not, unexpected cropping may occur. Please be aware the 0.5” top, bottom & sides will also be hidden in the channel of our metal system.

### Colour:

We digitally print in CMYK mode. All files should be saved for output in this mode to avoid unexpected results. If your logo/file contains specific Pantone Colours, please specify. We will match colours as closely as 4 colour process printing will allow.

**PLEASE SAVE ALL NATIVE ADOBE INDESIGN FILES AS PDF/X-1a.  
PLEASE BE AWARE THAT QUARK XPRESS IS NOT STANDARD.  
FILES CREATED IN QUARK SHOULD BE SAVED AS PDF/X-1a.**

If you experience technical difficulties  
please contact a GES representative@ 778.452.6226



GES is your one stop exhibit solution partner. Take advantage of our Creative Services Department to enhance your presence on the show floor. Upgrade a show special, or design from scratch. Our team of in-house Designers & Production Technicians, can help you realize your vision quickly and affordably.



- Backlit signs
- Banners & hanging signs
- Floor/carpet decals
- Backwall murals
- Easel & freestanding signs
- Posters
- Custom cut signs & decals
- Branding graphics

Please contact Dan Warcup 778.452.6226

or email: [dwarcup@ges.com](mailto:dwarcup@ges.com)

**Our Creative Exhibit Team will design a cost-effective, turnkey exhibit that will**

- ☉ Exceed your expectations
- ☉ Highlight your brand
- ☉ Attract positive attention
- ☉ Stay within your budget

**Your successful Tradeshow is just a phone call or click away...**

**Dan Warcup** ☎ 778.452.6226  
 ✉ [dwarcup@ges.com](mailto:dwarcup@ges.com)

20' x 20' island



10' x 20' inline



20' x 30' island



10' x 20' corner



# GRAPHICS ORDER FORM

<b>SHOW NAME:</b>	<b>VRIC 2014</b>	<b>DISCOUNT PRICE DEADLINE DATE:</b>	Friday, January 03, 2014
<b>SHOW DATE:</b>	<b>January 19-20, 2014</b>		

EXHIBITOR INFORMATION	CREDIT CARD AUTHORIZATION
<b>BOOTH #:</b> _____  COMPANY: _____ STREET: _____ CITY: _____ PROV/STATE: _____ CODE: _____ EMAIL: _____ PHONE: _____ FAX: _____ CONTACT NAME: _____	<p><b>NO ORDER WILL BE CONSIDERED FINAL UNTIL CREDIT CARD AUTHORIZATION FORM IS COMPLETED AND SUBMITTED WITH THIS FORM</b></p>

**ALL ORDERS MUST BE PREPAID IN FULL  
(ORDERS CANNOT BE PROCESSED UNTIL PAYMENT IS RECEIVED)**

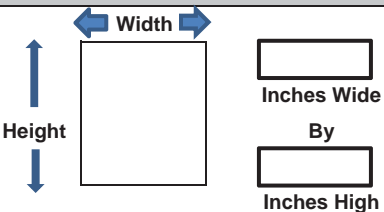
SIGN LAYOUT	QTY	SIGN SIZES	DISCOUNT PRICE	REGULAR PRICE
		11" x 14"	\$40.00	\$53.00
		14" x 22"	\$70.00	\$94.00
		22" x 28"	\$90.00	\$122.00
		7" x 44"	\$67.00	\$90.00
		28" x 44"	\$116.00	\$157.00
		40" x 60"	\$255.00	\$343.00
		Layout & Design Work / Hour	\$94.00	\$126.00

**CUSTOM ARTWORK / LOGOS MUST BE ORDERED NO LATER THAN 3 DAYS PRIOR TO FIRST DAY OF MOVE-IN**

**PLEASE PRINT OR TYPE THE WORKING REQUIRED:**

**PLEASE INDICATE FONT TYPE:** \_\_\_\_\_

**ALL SIGNS MUST BE PICKED UP FROM OUR ON-SITE EXHIBITOR SERVICES DESK**  
**Custom sizes available - Call for quotation.**  
TERMS AND CONDITIONS

ALL ORDERS RECEIVED AFTER THE DISCOUNT PRICE DATE WILL BE PROCESSED AT THE REGULAR PRICE.  
 THERE ARE NO REFUNDS / EXCHANGES ON SIGNS UNLESS ERROR LIES WITH GES PRODUCTION.  
 NO REFUNDS/EXCHANGES ONCE SHOW MOVE-IN BEGINS. ALL CLAIMS OR DISCREPANCIES MUST BE SETTLED PRIOR TO SHOW CLOSING.

<b>SUBTOTAL</b>	
<b>GST 5%</b>	
<b>PST 7%</b>	
<b>TOTAL</b>	
<b>INCLUDE TOTAL FROM THIS PAGE ON ORDER CHECKLIST SHEET</b>	

I HAVE READ AND UNDERSTAND THE TERMS & CONDITIONS OF MY AGREEMENT WITH GES.

\_\_\_\_\_  
SIGNATURE

\_\_\_\_\_  
DATE





# logistics

GES is proud to offer our clients a one source solution for Transportation services

## GES Logistics Services

### Your Choice of Reliable Service Options

- Time Critical Ground
- Expedited Ground
- 3-5 Day Deferred
- Common Carrier
- Van Line
- 30 Days Free Storage

### 24-Hour Tracking

Call toll free 1-800-636-8235 for immediate information on the status of your shipment

### On-Site Representation

GES Logistics representatives will be on site from the beginning of move-in and throughout the event until the last shipment leaves the show floor

### Competitive Pricing

You will benefit from priority delivery at competitive prices thanks to special arrangements we have with select carriers

### Simplified Budgeting

Our transportation management system gives you the information you need to budget more effectively

### Simplified Ordering

For your convenience choose one of the ordering options available:

- Online: [www.gesexpo.ca](http://www.gesexpo.ca)
- Phone: 403-243-2212 or 1-800-636-8235
- Fax: 403-243-3868

**Ship everywhere with GES Logistics Services.**







## **customs**

GES is proud to offer our clients a one source solution for Customs and Transportation services

## **GES Customs Services**

### **Reliable and Efficient Service**

- Experienced and reliable staff you can depend on who specialize in Tradeshow Customs procedures
- Personnel are accessible at all times

### **Value Added Service**

- Save time and money by making fewer calls

### **Personalized Service**

- Telephone, email and fax communication
- Forms and instructions for completion in all Exhibitor Service Kits
- One-on-one Customs consultation to assist all exhibitors with their specific needs

### **On-Site Representation**

GES Customs Services representatives will be on site from the beginning of move-in and throughout the event until the last shipment leaves the tradeshow floor

### **Simplified Ordering**

For your convenience choose one of the ordering options available:

- Online: [www.gesexpo.ca](http://www.gesexpo.ca)
- Phone: 403-243-2212 or 1-800-636-8235
- Fax: 403-243-3868

**Leave all your shipping, customs clearance and furniture rentals to GES.**

<b>SHOW NAME:</b>	<b>VRIC 2014</b>	<b>DISCOUNT PRICE</b>	
<b>SHOW DATE:</b>	<b>January 19-20, 2014</b>	<b>DEADLINE DATE:</b>	Friday, January 03, 2014

EXHIBITOR INFORMATION	CREDIT CARD AUTHORIZATION
<b>BOOTH #:</b> _____  COMPANY: _____  STREET: _____  CITY: _____ PROV/STATE: _____ CODE: _____  EMAIL: _____  PHONE: _____ FAX: _____  CONTACT NAME: _____	<p style="font-size: 1.2em; margin: 0;"><b>NO ORDER WILL BE CONSIDERED FINAL UNTIL CREDIT CARD AUTHORIZATION FORM IS COMPLETED AND SUBMITTED WITH THIS FORM</b></p>

**CREDIT CARD AUTHORIZATION (ABOVE) MUST BE COMPLETED AS METHOD OF PAYMENT FOR THIS SERVICE**

**ADVANCE SHIPMENT(S) TO WAREHOUSE:**

- Shipment(s) must be received by: _____ <b>41289</b>	
- Estimated Weight for Shipment(s) - Rounded up to the nearest 100 lbs:	_____ <b>POUNDS</b>
- Advance Warehouse Rate: <b>\$83.00</b> per 100 lbs. (200lb min. charge)	
<b>- Shipments arriving without a certified weight ticket will be subject to Special Handling rates,</b>	

**DIRECT SHIPMENT(S) TO SHOWSITE:**

- Shipment(s) may arrive at Show Site on or after: _____ <b>41657</b>	
- Estimated Weight OF Shipment(s) - Rounded up to the nearest 100 lbs:	_____ <b>POUNDS</b>
- Direct to Show Site Rate: <b>\$66.00</b> per 100 lbs. (200lb min. charge)	
<b>- Shipments arriving without a certified weight ticket will be subject to Special Handling rates,</b>	

**SMALL PACKAGES: (Maximum 50 lbs / Shipment)**

- Rate of: <b>\$52.00</b> for the First Package	
- Rate of: <b>\$36.00</b> for each additional package(s) (in the same shipment) to a 50lb. Maximum	
<small>**if shipment is over 50lbs, rates for advance or direct will apply.**</small>	

**SPECIAL HANDLING: (40% Surcharge Applies to the Entire Shipment)**

- Shipments of loose, padded or uncrated materials
- Special unloading requirements, such as ground and / or side door unloading, constricted or stacked unloading.
- All Direct and Advance Shipments without certified weight ticket or proven inaccurate weight ticket.
- Shipments arriving outside of target dates.

**PLEASE COMPLETE THE FOLLOWING:**

Carrier Name: _____	Number of Pieces: _____	Total Weight _____
Goods are scheduled for delivery to: <input type="checkbox"/>	Show Site <input type="checkbox"/>	Advance Warehouse <input type="checkbox"/>
Date goods are scheduled to arrive: _____ <span style="display: block; text-align: center; font-size: 0.8em;">Month/Day</span>		

**TERMS AND CONDITIONS**

- COLLECT SHIPMENTS WILL NOT BE ACCEPTED.
- GES IS NOT RESPONSIBLE FOR CONCEALED DAMAGE, DAMAGE TO LOOSE OR INADEQUATELY PACKED SHIPMENTS OR LOSS OF MERCHANDISE AFTER DELIVERY TO BOOTH
- IT IS THE EXHIBITORS RESPONSIBILITY TO SECURE AND MAINTAIN LOSS & DAMAGE INSURANGCE COVERAGE FOR THEIR EXHIBIT PROPERTIES.
- ALL CLAIMS OR DISCREPANCIES MUST BE SETTLED AT THE GES SERVICE CENTRE PRIOR TO SHOW CLOSING
- GES LIMITS OF LIABILITY & RESPONSIBILITY APPLY TO THIS SERVICE.

<b>SUBTOTAL</b>	
<b>GST 5%</b>	
<b>PST 7%</b>	
<b>TOTAL</b>	
INCLUDE TOTAL FROM THIS PAGE ON ORDER CHECKLIST SHEET	

I HAVE READ AND UNDERSTAND THE TERMS & CONDITIONS OF MY AGREEMENT WITH GES.

SIGNATURE	DATE
-----------	------



Material Handling is the unloading of your exhibit materials, delivery to your booth, handling of empty containers to and from storage, and removal of your materials from your booth for reloading onto your outbound carrier. This is not to be confused with the cost to transport your exhibit material to and from the event.

#### **Benefits of Advance Shipping to the GES Warehouse**

- Storage of materials for up to 30 days prior to your show.
- Delivery of Shipments to your booth by 8:00 AM on your first day of move-in (schedule permitting).
- Some convention centres and hotels do not have facilities for receiving or storing freight.
- Saves valuable set-up time.

#### **How to ship in Advance to the GES Warehouse**

- Remove all old shipping and empty storage labels.
- Fill out and attach enclosed Advance Shipping Labels.
- Complete the enclosed Advance Material Handling order form.
- All shipments must have a bill of lading or delivery slip showing the number of pieces, weight, and type of merchandise.
- Take the time to ensure that your display and products are packed neatly and securely.
- Do not ship uncrated materials to the warehouse.

#### **How to Ship to Exhibit Site**

- Consign all shipments c/o GES.
- Remove all old shipping and empty storage labels.
- Fill out and attach enclosed Direct Shipping labels.
- All shipments must have a bill of lading or delivery slip showing the number of pieces, weight, and type of merchandise.
- Take the time to ensure that your display and products are packed neatly and securely.
- If you are shipping your carpet and/or lighting trusses, make sure it is loaded last so it can be unloaded first.

#### **Freight Carriers**

Select a carrier with experience in handling exhibition materials. Make sure to give your carrier explicit information as to where and when to check-in. Delivery and pick up times are often out of the range of "normal" deliver hours, make sure your carrier is committed to meeting your target dates and times. While making shipping plans to the Show, also plan for the return shipment.

#### **Tracking Shipments**

Confirm your delivery date and time with your carrier, and have all pertinent shipping information in the hands of your representative at showsite. You may also want to review the return of your goods at the end of the show.

#### **Estimating Material Handling Charges**

Handling charges are based on the weight of the freight. Shipments are billed by the hundred weight and rounded up to the nearest hundred. Minimum per shipment may apply, see enclosed Material Handling Order Form for details. Please prepay all shipping charges - GES cannot accept or be responsible for collect shipments. Crated and uncrated shipments must be separated and clearly identified on your bill of lading.

- **Crated** - Material that is skidded, or is any type of shipping container that can be unloaded at the dock with no additional handling required.
- **Uncrated** - Material that is shipped loose or pad-wrapped, and/or unskidded machinery without proper lifting bars or hooks.
- **Special Handling** - Defined as shipments that are loaded by cubic space and/or packed in such a manner as to require special handling, such as ground loading, side door loading, constricted space loading, and designated piece loading or stacked shipments. Also included are mixed shipments and shipments without proper delivery receipts.

• **Overtime Surcharges** - Shows that move-in or move-out on weekends or late in the day may be subject to overtime surcharges. See enclosed Material Handling Order Form for details.

• **Late Surcharges** - A surcharge may apply if advance freight is received after the published deadline date for shipments to arrive at the warehouse. See enclosed Material Handling Order Form for details.

#### **Storing Empty Containers**

Properly labeled empty shipping cartons will be picked up, stored and returned after the show. Labels are available at the **GES Servicentre** or from your GES Service Executive and are for empty storage only. Depending on the size of the show, it can take from one (1) to four (4) hours to return empty crates. Do not store any items in crates marked empty.

#### **Outgoing Shipments**

An OMHF (Outbound Material Handling Form / Bill of Lading) must accompany all outgoing shipments. Shipping information, outbound forms and labels will be available at the **GES Servicentre**. Exhibitors selecting non-official carriers will need to make their own arrangements for pickup. Make sure that someone from your company will be on-site to oversee the outbound shipment of your display and product.

#### **Machinery Labour and Equipment**

Labour and equipment for uncrating, unskidding, positioning, leveling, dismantling, recrating, and reskidding machinery and/or equipment must be ordered separately. Place your order for this using the In-Booth Forklift and Labour Order Form. If your material requires specialized rigging equipment, please notify us promptly so that we can make arrangements. When possible supply your own rigging equipment with shipments and pre-rig your material

#### **Insurance**

All of your goods should be insured by your own insurance policy. Although we do our best to handle your goods as our own, there are many variables in shipping and handling that can affect your exhibit and products. GES has published GES Terms & Conditions of Contract that are in your exhibitor service manual. Please read them carefully. It is recommended that your goods be insured.

#### **Customs & Brokerage Fees**

GES is not responsible for the brokerage fees, duty or GST resulting from exhibitor materials entering Canada from another country. GES is not responsible for any delays in delivery of exhibitor materials to show site or the advance warehouse due to Canada Custom inspections or delays resulting from insufficient or improper documentation for shipments entering Canada from another country.

#### **GES CANADA Limits of Liability**

- **Liability** - GES is liable for loss or damage to your goods ONLY if the loss or damage was caused by GES negligence.
- **Measure of Damage** - If GES was negligent and the negligence caused either loss or damage to your goods, then the measure of that damage will be determined by the following:
  - a. Measure of damages in all situations (including b. below) will be limited by the Depreciated Value of the goods or repair costs, whichever is less.
  - b. The lesser of \$0.30 per pound per piece, \$50 per piece, or \$1000 per occurrence.GES does not offer or sell insurance. GES is not liable and will not owe for loss or damage to your goods if the damage was not caused by GES.

# ADVANCE WAREHOUSE SHIPPING LABEL

NAME OF SHOW:	VRIC 2014
FACILITY:	VCC-West Hall ABC

## EXHIBIT SHIPMENT FOR ADVANCE WAREHOUSE

**SHIPPER:**

\_\_\_\_\_  
(NAME OF COMPANY WHERE SHIPMENT ORIGINATES)

**TO:**

\_\_\_\_\_  
(NAME OF EXHIBITING COMPANY AT THE SHOW.)

**BOOTH #**

\_\_\_\_\_  
(BOOTH NUMBER AT THE SHOW.)

<b>ADVANCE WAREHOUSE ADDRESS</b>	GES C/O REIMER 3985 STILL CREEK AVENUE BURNABY, BC V5C 4E2
--	---

**CARRIER:**

\_\_\_\_\_  
(NAME OF TRANSPORTATION COMPANY)

**NUMBER**  **OF**  **PIECES**

**ADVANCE WAREHOUSE SHIPMENTS SHOULD ARRIVE BEFORE:**

Tuesday, January 15, 2013

**BETWEEN 9AM AND 3PM MONDAY - FRIDAY**

# DIRECT TO SHOW SITE SHIPPING LABEL

NAME OF SHOW:	VRIC 2014
FACILITY:	VCC-West Hall ABC

## EXHIBIT SHIPMENT FOR DIRECT TO SHOWSITE

**SHIPPER:**

\_\_\_\_\_  
(NAME OF COMPANY WHERE SHIPMENT ORIGINATES)

**TO:**

\_\_\_\_\_  
(NAME OF EXHIBITING COMPANY AT THE SHOW.)

**BOOTH #**

\_\_\_\_\_  
(BOOTH NUMBER AT THE SHOW.)

<b>SHOWSITE ADDRESS</b>	GES/	VRIC 2014
		1055 Canada Place Vancouver, BC V6C 0C3

**CARRIER:**

\_\_\_\_\_  
(NAME OF TRANSPORTATION COMPANY)

**NUMBER**  **OF**  **PIECES**

**DIRECT TO SHOW SITE SHIPMENTS TO ARRIVE ON:**

Saturday, January 18, 2014

**DURING EXHIBITOR MOVE-IN TIMES**

Unit 4 - 7978 N. Fraser Way Burnaby, BC V5J 0C7 Phone: 778.452.6220 Fax: 778.452.6221 Toll Free: 855.526.7182 vancouvercustomerservice@ges.com

<b>SHOW NAME:</b>	<b>VRIC 2014</b>	<b>DISCOUNT PRICE</b>	
<b>SHOW DATE:</b>	<b>January 19-20, 2014</b>	<b>DEADLINE DATE:</b>	Friday, January 03, 2014

**EXHIBITOR INFORMATION**

**BOOTH #:** \_\_\_\_\_

COMPANY: \_\_\_\_\_

STREET: \_\_\_\_\_

CITY: \_\_\_\_\_ PROV/STATE: \_\_\_\_\_ CODE: \_\_\_\_\_

EMAIL: \_\_\_\_\_

PHONE: \_\_\_\_\_ FAX: \_\_\_\_\_

CONTACT NAME: \_\_\_\_\_

**CREDIT CARD AUTHORIZATION**

NO ORDER WILL BE CONSIDERED  
FINAL UNTIL CREDIT CARD  
AUTHORIZATION FORM IS COMPLETED  
AND SUBMITTED WITH THIS FORM

**ALL ORDERS MUST BE PREPAID IN FULL  
(ORDERS CANNOT BE PROCESSED UNTIL PAYMENT IS RECEIVED)**

LABOUR RATES LISTED ARE PER PERSON PER HOUR AT A **MINIMUM CHARGE OF ONE (1) HOUR**. LABOUR OVER ONE (1) HOUR IS CHARGED IN HALF (1/2) HOUR INCREMENTS.

(A 40% SURCHARGE WILL BE APPLIED TO ALL ONSITE ORDERS)

**STRAIGHT TIME**  
**8:00am-4:00pm**  
**Monday-Friday**

\$116.00

**OVERTIME**  
**4:00PM-6:00PM**  
**Monday-Friday**  
**8:00am-4:00pm Sat&Sun**

\$174.00

**DOUBLE TIME**  
**After 6:00pm Mon -Fri**  
**After 4:00pm Sat & Sun & Holidays**

\$232.00

**EXHIBITOR MUST REPORT TO GES SERVICE CENTRE TO RECEIVE THEIR LABOUR**

**INSTALLATION**      Set up Drawings or Photos Attached:  YES     NO

Carrier: \_\_\_\_\_ Delivery Date : \_\_\_\_\_ Delivery time: \_\_\_\_\_  
(Day/Date/Month/Year) (indicate am or pm)

**SUPERVISION**     By Exhibitor (Provide Name of Rep)       By GES (30% Surcharge Applies)  
(Exhibitor MUST be Present to Supervise) (Exhibitor Does not have to be present)

Date Labour Required: \_\_\_\_\_ Start time Required: \_\_\_\_\_  AM  PM  
(Day/ Date/Month/Year)

Number of People Required:  X Hours Per Person  = Total Hours

**DISMANTLING**

Carrier: \_\_\_\_\_ Delivery Date : \_\_\_\_\_ Delivery time: \_\_\_\_\_  
(Day/Date/Month/Year) (indicate am or pm)

**SUPERVISION**     By Exhibitor (Provide Name of Rep)       By GES (30% Surcharge Applies)  
(Exhibitor MUST be Present to Supervise) (Exhibitor Does not have to be present)

Date Labour Required: \_\_\_\_\_ Start time Required: \_\_\_\_\_  AM  PM  
(Day/ Date/Month/Year)

Number of People Required:  X Hours Per Person  = Total Hours

**TERMS AND CONDITIONS**

WHEN EXHIBITOR IS SUPERVISING LABOUR THE EXHIBITOR MUST CHECK LABOUR IN AND OUT AT THE GES SERVICE CENTRE.  
 WE RESERVE THE RIGHT TO CHANGE LABOURERS AND/OR RATES AS SHIFTS CHANGE.  
 ALL CLAIMS OR DISCREPANCIES MUST BE SETTLED AT THE GES SERVICE CENTRE PRIOR TO SHOW CLOSING.  
 UNCANCELLED LABOUR WILL BE CHARGED A MINIMUM FEE OF 1 HOUR PER PERSON.  
 GES LIMITS OF LIABILITY APPLY

<b>SUBTOTAL</b>	
<b>GST 5%</b>	
<b>TOTAL</b>	
INCLUDE TOTAL FROM THIS PAGE ON ORDER CHECKLIST SHEET	

I HAVE READ AND UNDERSTAND THE TERMS & CONDITIONS OF MY AGREEMENT WITH GES.

\_\_\_\_\_  
SIGNATURE

\_\_\_\_\_  
DATE

Unit 4 - 7978 N. Fraser Way Burnaby, BC V5J 0C7 Phone: 778.452.6220 Fax: 778.452.6221 Toll Free: 855.526.7182 [vancouvercustomerservice@ges.com](mailto:vancouvercustomerservice@ges.com)

<b>SHOW NAME:</b>	<b>VRIC 2014</b>	<b>DISCOUNT PRICE</b>	
<b>SHOW DATE:</b>	<b>January 19-20, 2014</b>	<b>DEADLINE DATE:</b>	Friday, January 03, 2014
<b>EXHIBITOR INFORMATION</b>		<b>CREDIT CARD AUTHORIZATION</b>	

**BOOTH #:** \_\_\_\_\_

**COMPANY:** \_\_\_\_\_

**STREET:** \_\_\_\_\_

**CITY:** \_\_\_\_\_ **PROV/STATE:** \_\_\_\_\_ **CODE:** \_\_\_\_\_

**EMAIL:** \_\_\_\_\_

**PHONE:** \_\_\_\_\_ **FAX:** \_\_\_\_\_

**CONTACT NAME:** \_\_\_\_\_

**NO ORDER WILL BE CONSIDERED  
FINAL UNTIL CREDIT CARD  
AUTHORIZATION FORM IS COMPLETED  
AND SUBMITTED WITH THIS FORM**

**CREDIT CARD AUTHORIZATION (ABOVE) MUST BE COMPLETED AS  
METHOD OF PAYMENT FOR THIS SERVICE**

IN-BOOTH FORKLIFT SERVICE IS AVAILABLE TO EXHIBITORS REQUIRING ASSISTANCE WITH POSITIONING OF EXHIBITORS MATERIAL **WITHIN YOUR YOUR BOOTH SPACE. MINIMUM CHARGE OF ONE HOUR** PER SHIPMENT **PER FORKLIFT DRIVER**. SERVICES OVER ONE (1) HOUR WILL BE CHARGED IN HALF (1/2) HOUR INCREMENTS (INCLUDES MOVE-IN AND MOVE-OUT)

**THIS SERVICE IS NOT PAID FOR BY SHOW MANAGEMENT**

**ALL RATES INCLUDE ONE (1) FORKLIFT AND DRIVER - ADDITIONAL RATES WILL APPLY FOR ADDITIONAL PERSONNEL AND EQUIPMENT**

<p><b>STRAIGHT TIME</b> 8:00am-4:00pm Monday-Friday</p> <p style="font-size: 1.2em;">\$128.00</p>	<p><b>OVERTIME</b> 4:00PM-6:00PM Monday-Friday 8:00am-4:00pm Sat&amp;Sun</p> <p style="font-size: 1.2em;">\$192.00</p>	<p><b>DOUBLE TIME</b> After 6:00pm Mon -Fri After 4:00pm Sat &amp; Sun &amp; Holidays</p> <p style="font-size: 1.2em;">\$256.00</p>
---	--	---

**A 40% SURCHARGE WILL APPLY TO ALL ONSITE ORDERS.**

**ALL RATES INCLUDE FROKLIFT AND DRIVER (5% GST IS APPLICABLE)**

**PLEASE COMPLETE THE FOLLOWING**

**SUPERVISOR NAME:** \_\_\_\_\_ **(EXHIBITOR MUST BE PRESENT TO SUPERVISE)**

**INSTALLATION TIME REQUIRED:** \_\_\_\_\_

DAY                      DATE                      MONTH                      # of HOURS                      #of FORKLIFTS

**DISMANTLING TIME REQUIRED:** \_\_\_\_\_

DAY                      DATE                      MONTH                      # of HOURS                      #of FORKLIFTS

**APPROXIMATE TIMES ONLY - FORKLIFTS WILL BE DISPATCHED BY REQUEST PLACED AT EXHIBITOR SERVICES DESK ONSITE**

<b>MOVE-IN</b>	<b>START:</b>	<input type="checkbox"/> AM	<input type="checkbox"/> PM	<b>FINISH:</b>	<input type="checkbox"/> AM	<input type="checkbox"/> PM	<b>TOTAL HOURS:</b> _____
<b>MOVE-OUT</b>	<b>START:</b>	<input type="checkbox"/> AM	<input type="checkbox"/> PM	<b>FINISH:</b>	<input type="checkbox"/> AM	<input type="checkbox"/> PM	<b>TOTAL HOURS:</b> _____

**SERVICES OVER 1 HOUR MINIMUM WILL BE CHARGED IN 1/2 HOUR INCREMENTS PER FORKLIFT**

**TERMS AND CONDITIONS**

- EXHIBITOR MUST CHECK FORKLIFT / DRIVER IN AND OUT AT THE GES SERVICE CENTRE.
- WE RESERVED THE RIGHT TO CHANGE LABOURERS AND / OR RATES AS SHIFTS CHANGE.
- FORKLIFT OPERATORS RESERVE THE RIGHT TO REFUSE UNSAFE REQUESTS OR LIFTS AT ALL TIMES.
- IT IS THE EXHIBITORS RESPONSIBILITY TO SECURE AND MAINTAIN LOSS & DAMAGE INSURANCE COVERAGE FOR THEIR EXHIBIT PROPERTIES.
- ALL CLAIMS OR DISCREPANCIES MUST BE SETTLED AT THE GES SERVICE CENTRE PRIOR TO SHOW CLOSING
- GES LIMITS OF LIABILITY & RESPONSIBILITY APPLY TO THIS SERVICE.

<b>SUBTOTAL</b>	
<b>GST 5%</b>	
<b>PST 7%</b>	
<b>TOTAL</b>	

**INCLUDE TOTAL FROM THIS PAGE  
ON ORDER CHECKLIST SHEET**

I HAVE READ AND UNDERSTAND THE TERMS & CONDITIONS OF MY AGREEMENT WITH GES.

\_\_\_\_\_  
SIGNATURE

\_\_\_\_\_  
DATE

## **factoring green**



### **Into your event**

#### **Green Philosophy**

GES is dedicated to being good stewards of our environment, by providing green product options and services to all our event organizers and exhibitors. As the need to conserve resources grows, we will continue to explore ways to deliver sustainable solutions.

#### **Green Teams**

As a value-based company providing innovative solutions, we are constantly striving to put our Green Philosophy into practice. Each Canadian city or region has implemented a Green Advocate who is responsible to discuss, evaluate, communicate and implement local as well as national opportunities.

#### **Eco-friendly Advantages**

We are a certified transport partner in the EPA SmartWay Transport Partnership program to increase energy efficiency while considerably reducing emissions.



#### **Facility Relationships**

GES is fortunate to be considered the official or preferred supplier in all of our associated facilities across Canada. Because of these strong relationships within the facilities and their team members, we are able to take advantage of temporary and permanent equipment storage areas. This allows us the opportunity to consolidate equipment needs for subsequent events and minimize transportation emissions.

#### **Warehousing**

Each GES office has a warehouse close to the major facilities. Because of the proximity to parts and equipment, transportation emissions are reduced.



# GES Environmentally Responsible Products and Efforts

**Bioboard** - made of 60% recycled content and 100% recyclable; alternative to foamcore used for graphic panels

**Bamboo Banner Stands** - we use eco-intelligent polyester and water based inks

**Biobanner** - will oxo-biodegrade in landfill in as little as 9 months; alternative to vinyl banner

**Carpet Under Padding** - GES uses carpet under padding made from 100% recycled synthetic fibers

**Carpet Recycling Program** - when carpet can no longer be used as aisle or booth carpet, it is recycled for other uses such as covering dollies or lining crates

**Cleaning Supplies** - GES and its cleaning contractors use biodegradable and non-toxic cleaning supplies

**Eco-Friendly Carpet Choices** - our Pepper and BlueJay coloured carpets are 100% recyclable

**Exhibitor Kit Paper Reduction** - In 2009, 90% of GES Exhibitor Kits were provided electronically in lieu of standard paper kits

**GES Online** - allows exhibitors to place orders online, reducing the use of paper

**Graphics** - we use water based inks in our digital printers that produce little to no VOCs and retrieve recyclable graphic material at showsite to repurpose and/or recycle

**Graphic Storage** - graphic panels are collected from showsite and stored in our warehouse to be used the next year; we encourage our clients not to put dates on graphics and to reuse a “look” for several years

**Ink Cartridges and Printheads** - 100% recyclable; we partner with HP’s Planet Partners program

**Office Supplies** - GES purchases recycled/recyclable office supplies

**Panel Inserts** - we use LEED compliant and formaldehyde-free composite wood

**Q-tops** - 100% recyclable, form fitted vinyl table covers used to top tables with no waste

**Recycle** - GES offices and warehouses recycle paper, cardboard, aluminum, wood, plastic, and Plexiglas

**Visqueen** - GES uses visqueen that is 100% recyclable and made from 50% recycled content

GES is currently working with vendors to develop more eco-friendly, cost effective alternatives. We continue to raise the bar, seeking environmental solutions that make sense for our clients, the environment and our company.

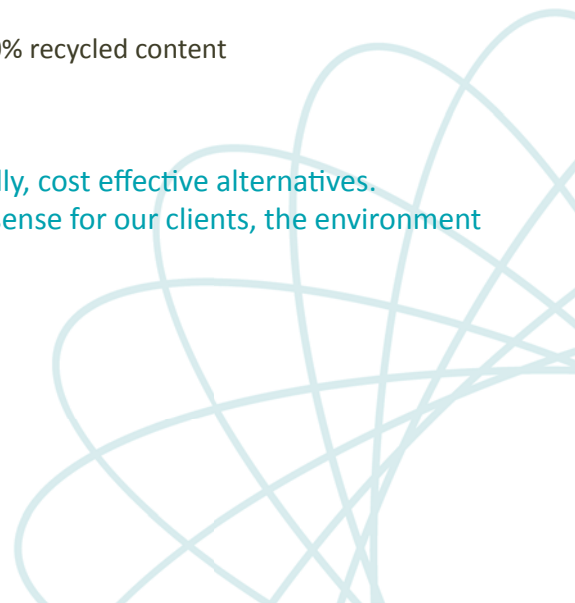



# Eco-friendly Events

For many years we have provided modular system structures made from recycled aluminum. These structures/exhibits are installed and dismantled for numerous events and returned to our warehouse to be reconfigured and reused. Now we are able to compliment these structures with infill panels and graphics that allow our clients to reach their “green” vision.

## IIDEX/NeoCon



As Canada’s largest exposition and conference for the design, construction and management of the built environment, IIDEX/NeoCon Canada has recently launched a three year initiative to make their event more sustainable by using green suppliers and contractors. They have been working to create a carbon neutral show as well as collaborating with the facility they work within to reduce the total environmental footprint of the event. GES is proud to partner with MMPI to provide innovations and products such as our 100% recyclable aisle carpet.

## International Council of Shopping Centres



In 2009 ICSC made arrangements with LivClean to help provide clean power and carbon offsets in exchange for booth space. They also implement standard procedures for their show such as recycling badge holders, no plastic bags, and water stations instead of bottled water. GES was able to provide environmentally friendly graphic substrate and media options as well as the repurposing of returned graphic panels.

## Green Living



In conjunction with the Green Living Show’s own green initiatives, GES was able to offer biodegradable signage to meet their “Green Screen” standards. All suppliers are evaluated and assessed for environmental performance in business activities directly related to their supply chain, operations, products and/or services.

## Canada Green Building Council



The mission of the CGBC is to lead and accelerate the transformation to high-performing, healthy green buildings, homes and communities throughout Canada with the end vision being a transformed built environment leading to a sustainable future. GES was proud to provide bioboard and biobanner signage as well as 100% recyclable carpet for this client.

## Futurallia Québec



An international business event, for their part selected the Zero Waste with Offsets package, in collaboration with the Foundation de la Faune du Québec. “We are aware of our participants’ concern with these issues. In addition to reducing our waste, we would like to show the way through actions that benefit Québec’s biodiversity” GES was directly involved with the organizing committee and followed through on its commitments to reduce the waste associated with the exhibit portion of the event as well as to recycle all event signage and graphics.

#### **I. Definitions:**

**Agents:** GES's agents, sub-contractors, carriers, and the agents of each.

**Customer:** Exhibitor or other party requesting services from GES.

**Carrier:** Motor carrier, van line, air carrier, or air or surface carrier/freight forwarder.

**Shipper:** Party who tenders Goods to Carrier for transportation.

**Goods:** Exhibits, property, and commodities of any type for which GES is requested to perform services.

**Cold Storage:** Holding of Goods in a climate controlled area.

**Accessible Storage:** Holding of Goods in an area from which Goods may be removed during shows.

**Services:** Warehousing, transportation, drayage, un-supervised labour, supervised labour and/or related services.

**Show Site:** The venue or place where an exposition or event takes place.

**Supervised Labour:** Labour that is provided to a Customer to install or dismantle a booth or exhibit space, and is supervised and/or directed by GES.

**Un-Supervised Labour:** Labour that is provided to a Customer to install or dismantle a booth or exhibit space and per Customer's election is not supervised and/or directed by GES. Customer assumes the responsibility for the work of labour when Customer elects to use unsupervised labour.

#### **II. Scope:**

These Terms and Conditions shall be binding upon Customer, GES, and their respective Agents and representatives, including but not limited to Customer contracted labour such as Customer Appointed Contractors and Installation and Dismantle Companies, and any other party with an interest in the Goods. Each shall have the benefit of and be bound by all provisions stated herein, including but not limited to time limits and limitations of liability.

**By acceptance of services of GES or Agents, Customer and any other party with an interest in the Goods agree to these Terms and Conditions.**

#### **III. Customer Obligations:**

**Payment for Services.** Customer shall be liable for all unpaid charges for services performed by GES or Agents. Customer authorizes GES to charge its' credit card directly for services rendered on its' behalf after departure, by placing an order on-line, via fax, phone, or through a work order on site.

**Credit Terms.** All charges are due before Services are performed unless other arrangements have been made in advance. GES has the right to require prepayment or guarantee of the charges at the time of request for Services. A failure to pay timely will result in Customer having to pay in cash in advance for future services. If a credit provided to GES, GES is authorized to bill to such credit card any unpaid charges for services provided Customer, including charges for return shipping. Any charges not paid within 30 days of deliver will be subject to interest at 1.5% per month until paid.

#### **IV. Mutual Obligations:**

##### **Indemnification:**

**Customer to GES:** Except to the extent of GES's own negligence and/or willful misconduct, Customer shall defend, hold harmless and indemnify GES from and against any claims, lawsuits, demands, liability, costs, and expenses, including reasonable attorney's fees and court costs, resulting from any injury to or death of persons, or damage to property, relating to or arising from performance under this Agreement.

Customer agrees to indemnify and hold GES harmless for any and all acts of its representatives and agents,

including but not limited to Customer Appointed Contractors and Installation and Dismantle Companies, any subtenant or other user of its' space or any agents or employees engaged in business on its' behalf of Customer or present at Customers' invitation.

**GES to Customer:** To the extent of GES's own negligence and/or willful misconduct, and subject to the limitations of liability below, GES shall defend, hold harmless and indemnify Customer from and against any claims, lawsuits, demands, liability, costs and expenses, including reasonable attorney's fees and court costs, resulting from any injury to or death of persons, or damage to property other than Goods. GES assumes no liability for bodily injury resulting from Customer's presence in areas which have been marked as "off limits to exhibitors" and during hours and days when exhibitors are present in the facility, prior to the start of and after the conclusion of their space lease with show management.

**V. No liability for consequential damages. UNDER NO CIRCUMSTANCES WILL ANY PARTY BE LIABLE FOR SPECIAL, INCIDENTAL, CONSEQUENTIAL OR PUNITIVE DAMAGES, INCLUDING BUT NOT LIMITED TO LOSS OF PROFITS OR INCOME.**

#### **VI. GES Liability for Loss or Damage to Goods**

**Negligence standard:** GES shall be liable, subject to the limitations contained herein, for loss or damage to Goods only if such loss or damage is caused by the direct negligence or willful misconduct of GES.

**Condition of Goods:** GES shall not be liable for damage, loss, or delay to uncrated freight, freight improperly packed, glass breakage or concealed damage. GES shall not be liable for ordinary wear and tear in handling of Goods or for damage to shrink wrapped Goods. All Goods should be able to withstand handling by heavy equipment, including but not limited to forklifts, cranes, or dollies. It is the Customers' responsibility to ensure that Goods are packaged correctly prior to shipment or movement on or off the Show floor.

**Receipt of Goods:** GES shall not be liable for Goods received without receipts, freight bills, or specified unit counts on receipts or freight bills. Such Goods shall be delivered to booth without the guarantee of piece count or condition.

**Force Majeure:** GES shall not be liable for loss or damage that results from Acts of God, weather conditions, act or default of Customer, shipper, or the owner of the Goods, inherent nature of the Goods, public enemy, public authority, labour disputes, and acts of terrorism or war.

**Cold Storage:** Goods requiring cold storage are stored at Customer's own risk. GES assumes no liability or responsibility for Cold Storage.

**Accessible Storage:** GES assumes no liability for loss or damage to Goods while in Accessible Storage. Storage charges are for the use of space and are not a form of insurance, or a guarantee of security.

**Unattended Goods:** GES assumes no liability for loss or damage to unattended Goods received at Show Site at any time from the point of receipt of inbound Goods until the loading of the outbound Goods, including the entire term of the respective show or exhibition. Customer is responsible for insuring its' own Good for any and all risk of loss.

**Labour:** GES assumes no liability for loss, damage, or bodily injury arising out of Customer's supervision of GES provided labour. If GES supervises labour for a fee, GES shall be liable only for actions or claims arising out of its' negligent supervision. If Customer elects to use unsupervised labour, then Customer assumes all liability for the actions or claims that arise out of such work, and shall provide GES and show management with an indemnity, including defense costs, for any claims that result from Customers' supervision or failure to supervise assigned labour.

**Empty Storage:** GES assumes no liability for loss or damage to Goods or crates, or the contents therein, while containers are in storage. It is the Customer's sole responsibility to affix the appropriate labels available at the GES Service Desk for empty container storage. Damage that is the direct result of GES's negligence shall be subject to the limitations of liability set forth in this document.

**Forced Freight:** GES shall not be liable for Goods not picked up by Customer's chosen carrier by the show deadline. It is the Customer's responsibility to complete accurate paperwork for shipping and ensure its' Goods are appropriately labeled. Customer acknowledges that it is a lessee of space, and as such has an obligation to remove its' Goods on or before the targeted time. If Goods remain on the floor after this point, GES has the right to remove them in order to restore the premises to its original condition for show management pursuant to the venue's lease with show management. In such cases GES is authorized to proceed in the manner chosen Customer on the Order for Material Handling Services/ Straight Bill of Lading. Failure to select on of the provided options will result in re-routing at GES's discretion, and at Customer's expense assuming the Goods are labeled for return. GES retains the right to dispose of Goods left on the show floor without liability if left unattended, left without labels or not correctly labeled.

**Concealed Damage:** GES shall not be liable for concealed loss or damage, uncrated Goods, or improperly package or labeled Goods.

**Unattended Booth:** GES shall not be liable for any loss or damage occurring while Goods are unattended in Customer's booth at any time, including, but not limited to, the time the Goods are delivered to the dock until the time the Goods are received by Customer's chosen carrier. All Material Handling Forms and/or Straight Bills of Lading covering outgoing Goods submitted to GES will be checked at the time of pickup from the booth and corrections to the count or condition will be documented where discrepancies exist.

**Measure of Damage:** GES's liability shall be limited to the lesser of 1) the depreciated value of Goods, 2) repair cost, or 3) the limitation of liability. The limitation of liability shall be \$0.30 (thirty cents) per pound per piece, \$50 (fifty dollars) per article or \$1000.00 (one thousand dollars) per shipment.

**No Insurance:** GES is not an insurance company and does not offer or provide insurance. It is the obligation of Customer to ensure Goods are insured at all times. Loss or theft of the Goods in storage or in transit to and from the show and or while on the show floor is the sole responsibility of Customer, unless it is shown that GES performed in a manner that constitutes gross negligence in the performance of its services for Customer.

**Notice of loss or damage:** In order to have a valid claim, notice of loss or damage to Goods must be given to GES within 24 hours of occurrence or delivery of Goods, whichever is later.

**Filing of Claim:** Any claim for loss or damage to Goods must be in writing, containing facts sufficient to identify the Goods, asserting liability for alleged loss or damage, and making claim for the payment of a specified or determinable amount of money. Such claim must be filed with the appropriate party within the time limits specified below.

Damage Reports, incident reports, inspection reports, notations of shortage or damage on freight bills or other documents, do not constitute filing of a claim.

Claim for goods alleged to be lost, stolen or damaged at the Show Site must be received in writing by GES within sixty (60) days after the close of the show.

Claims for Goods alleged to be lost or damaged during transit must be received by the responsible party within nine (9) months of the date of delivery of Goods. GES Logistics subcontracts the movement of Goods to third party carriers. Claims for damage in transit should be made directly with the Customer's carrier as shown on the Material Handling form / Straight Bill of Lading. In the event of a dispute with GES, Customer will not withhold payment or any amount due GES for Services as an offset against the amount of the alleged loss or damage. Customer agrees to pay GES prior to the close of the show for all such charges and further agrees that any claim Customer may have against GES shall be pursued independently by Customer as a separate action to be resolved on its own merits. GES reserves the right to pursue collection on amounts owed after show close, without regard to any amount alleged to be owed for damage, or loss.

**Filing of Suit:** Any action at law regarding loss or damage to Goods must be filed within one (1) years of the date of declination of any part of a claim.

#### **VII. Jurisdiction, Choice of Forum.**

This Agreement shall be governed by and construed in accordance with the applicable laws of Canada or, alternatively, and depending on jurisdiction, the laws of the Province of British Columbia.

#### **VIII. Advance Warehousing / Temporary Storage / Long Term Storage.**

All terms and conditions relative to Advanced Warehousing / Temporary Storage / Long Term Storage are contained in the separate agreement entitled "Storage Agreement". In the event that a Storage Agreement is not executed between the parties, the following shall apply with respect to GES's liability for Customer's Goods:

The responsibility of GES with respect to Exhibit Material is limited to the exercise of ordinary care and diligence in handling and storing of Customer's Goods. GES shall be liable only for loss or damage to Goods caused by GES's sole negligence. GES's liability is limited to sixty (\$0.60) cents per pound or the actual cash value per article. In the case of partial loss or damage, the maximum liability shall be prorated based on weight. GES is not responsible for any loss or damage to Goods caused by, but not limited to fire, theft, the elements, vandalism, moisture, vermin, mechanical breakdown or failure, freezing or changes in temperature, as well as any other causes beyond GES's immediate control. GES is not responsible for the marring, scratching, or breakage of glass or other fragile items. GES is not liable for the mechanical functions of instruments or appliances even if such articles are packed or unpacked by GES. In no event shall GES be liable for special, incidental, indirect, or consequential damages, including business loss of any kind, resulting from any damage to or loss of Goods or from any act or failure to act. Customer pays storage fees, if any or costs for advance warehousing for use of the space only. There is no guarantee of security or representations made by GES as to appropriateness of the conditions for Exhibitors' Material. This risk of loss remains the Customer's alone and GES recommends the Customer carry and maintain insurance in amounts sufficient to cover its risk.

**SPECIAL NOTE: THE CONSIGNMENT OR DELIVERY OF A SHIPMENT TO GES OR ITS SUBCONTRACTORS BY A CUSTOMER OR BY ANY SHIPPER ON BEHALF OF THE CUSTOMER SHALL BE CONSTRUED AS AN ACCEPTANCE BY SUCH EXHIBITOR (AND/OR OTHER SHIPPER) OF THE TERMS AND CONDITIONS SET FORTH IN THIS AGREEMENT.**