



Society of Petroleum Engineers

Society of Petroleum Engineers

Exhibit Regulations

**SPE Canada Unconventional Resources
Conference & SPE Canada Heavy Oil
Technical Conference**

15-16 February

**BMO Centre at Stampede Park
Calgary, Alberta, Canada**

Exhibit Regulations

2017 SPE Canada Unconventional Resources Conference & 2017 SPE Canada Heavy Oil Technical Conference

Table of Contents

Section	Page
1 Introduction	4
2 Official Service Contractors	4
2.1 Exclusive Contracted Services	4
3 Stand Configuration	4
3.1 Booth Display Types	4
3.1.1 Linear Booth	4
3.1.2 Perimeter Booth	5
3.1.3 Peninsula / Split Island Booth	5
3.1.4 Walk-Thru Booths	6
3.1.5 Island Booth	6
3.2 Weight Restrictions	7
3.3 Multi-Level Booths	7
3.4 Hanging Signs & Graphics Guidelines	8
4 Build up and Breakdown	10
4.1 Construction	10
4.2 Electrical	11
4.3 Decorating	11
4.4 Lighting	12
4.5 Carpeting	12
4.6 Installation/Dismantle Schedule	13
4.6.1 After Hours Work Permits	13
4.6.2 Unattended Freight	13
4.7 Booth Inspection Deadline (No-Show Ruling)	13
4.8 Early Tear Down	14
5 Health and Safety	14
5.1 General Safety Procedures	14
5.2 Alcohol	14
5.2.1 Consumption of Alcohol	14
5.3 Fire and Safety Procedures	14
5.3.1 Aisles	14
5.3.2 Fire Regulations	15

Exhibit Regulations

2017 SPE Canada Unconventional Resources Conference & 2017 SPE Canada Heavy Oil Technical Conference

5.3.3	Indoor Display of Vehicles	16
5.4	Security	16
6	Utilities and Services	16
6.1	Electrical	16
6.2	Catering	16
6.3	Cleaning and Waste Disposal	17
6.4	Internet	17
7	Character of Exhibit	17
7.1	Good Neighbor Policy	19
7.2	Noise	19
7.3	Copyright Regulations	19
7.4	Hospitality Functions	20
8	Insurance	20
9	Employment and Venue Regulations	20
9.1	Smoking Policy	20
9.2	Employment of Labor/ Union Jurisdiction	21
9.3	Age Restrictions to Exhibit Areas	21
9.4	Parking	21
10	Photography, Recording and Advertising	21
10.1	Photography/Video/Audio Recording Regulations	21
10.2	Marketing and Advertising	22
10.3	Solicitation	23
10.4	Market Research and Surveys	23
10.5	Registration Lists/Lead Retrieval	23
11	Exhibitor-Appointed Contractors (EAC)	23
11.1	Exhibitor Responsibilities	24
11.2	Exhibitor-Appointed Contractor Responsibilities	24
11.3	Rules and Regulations Governing Exhibitor-Appointed Contractors	25
12	SPE Show Management's Discretionary Rights	26
13	Amendments	26

Exhibit Regulations

2017 SPE Canada Unconventional Resources Conference & 2017 SPE Canada Heavy Oil Technical Conference

1 Introduction

SPE has developed these exhibit regulations in order to provide a well-balanced, well-regulated, attractive and successful show. No exceptions to these regulations will be permitted. SPE reserves the right to enforce strict compliance with these Exhibit Regulations. Each exhibitor (“Exhibitor”) understands and agrees that the Exhibit Regulations are an integral and binding part of the Exhibit Space Agreement.

Exhibitors are responsible for all their company personnel, and as such are responsible for communicating these Exhibit Regulations as well as all rules to their employees. Ignorance of a regulation is no excuse for a violation. Exhibiting personnel found in violation of the Exhibit Regulations, especially the Photography/Video/Audio Recording Regulations, are subject to removal from the SPE Canada Unconventional Resources Conference & SPE Canada Heavy Oil Technical Conference. Multiple offenses by personnel of the same exhibiting booth/company will subject that company to having its booth closed for the remainder of the event and all of its personnel being removed from the SPE Canada Unconventional Resources Conference & SPE Canada Heavy Oil Technical Conference. This will also subject that same company to losing priority points and up to and including losing the ability to exhibit at future SPE events.

2 Official Service Contractors

To ensure the continuation of a smooth installation, dismantling and operation during the Exhibition, Official Contractors have been appointed. Although full-time employees of Exhibitor-Appointed Contractors, other than the Official Contractors, may be authorized to gain access to exhibition areas, Exhibitors are urged to obtain required labor and services from SPE Official Contractors. Complete details of Official Contractors are provided within the Exhibitor Services Manual.

2.1 Exclusive Contracted Services

The services listed below must be provided by the Exclusive SPE Contractor. No other company will be given permission for the performance of these services:

- Electrical, Plumbing and other Utilities – BMO Centre at Stampede Park
- Telephone/Communications/Internet/Network – BMO Centre at Stampede Park
- Drayage/Forklift Operations - GES
- Rigging – Overhead or Genie Lift – BMO
- Booth Catering – BMO Centre at Stampede Park

3 Stand Configuration

3.1 Booth Display Types

3.1.1 Linear Booth

A standard/linear (10'x10') booth (also called “in-line booth”) is any booth that shares a common back wall and adjoins other exhibits on one or two sides.

NOTE: A booth that is 10 ft. in depth but has 2 corners and no adjoining booths is also considered a linear booth and is subject to the height restrictions of a linear booth.

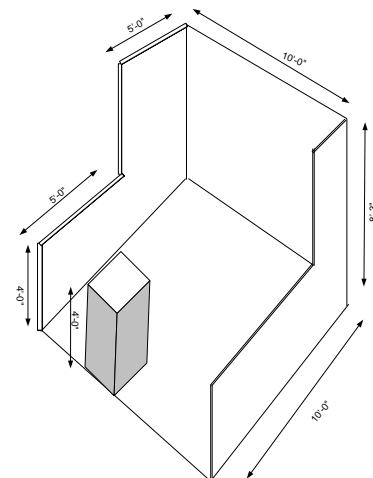

Exhibit Regulations

2017 SPE Canada Unconventional Resources Conference & 2017 SPE Canada Heavy Oil Technical Conference

The maximum back wall height is eight-feet three-inches (8'3"), including truss, and is allowed only in the rear half of the booth space.

Exceptions to the 8-foot maximum booth height may be extended to physical equipment that exceeds the maximum height restrictions. This does not include the physical exhibit structure. Every attempt should be made to display this equipment in the back 5ft of the booth to allow visibility for neighboring booths. Any graphics on physical equipment must follow the in-line height guidelines (not to extend over 8'3" in the rear half of the booth or over 4' in the front half of the booth). Exceptions are at the discretion of SPE.

A four-foot (4') height restriction is imposed on all materials in the remaining space forward to the aisle.

NOTE: When three or more Linear Booths are used in combination as a single exhibit space, the 4ft (1.22m) height limitation is applied only to that portion of exhibit space which is within 10ft (3.05m) of an adjoining booth.

Exhibitor must leave room for back pipe and drape to be shared between its booth and the booth behind it. Booth should not be set so that the plate for the pipe and drape is completely in a neighboring booth.

Hanging signs/graphics are **NOT** permitted over standard/linear booths.

3.1.2 Perimeter Booth

A Perimeter Booth (10'x10') is a standard/linear booth that backs to an outside wall of the exhibit facility rather than to another exhibit.

The maximum back wall height is twelve feet (12') including truss, and is allowed only in the rear half of the booth space.

Exceptions to the 12-foot maximum booth height may be extended to physical equipment that exceeds the maximum height restrictions. This does not include the physical exhibit structure. Every attempt should be made to display this equipment in the back 5ft of the booth to allow visibility for neighboring booths. Any graphics on physical equipment must follow the in-line height guidelines (not to extend over 12' in the rear half of the booth or over 4' in the front half of the booth). Exceptions are at the discretion of SPE.

A four-foot (4') height restriction is imposed on all materials in the remaining space forward to the aisle.

Hanging signs/graphics are **NOT** permitted over standard/ linear perimeter booths.

3.1.3 Peninsula / Split Island Booth

A peninsula booth is any exhibit 20'x20' or larger with a depth from the common back wall to the aisle of at least 20' and with aisles on three (3) sides.

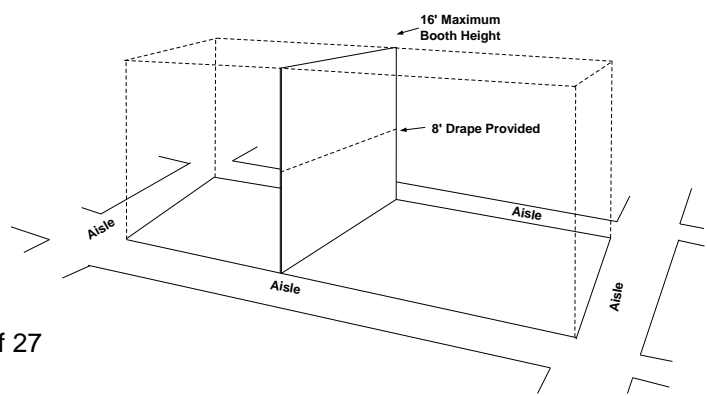
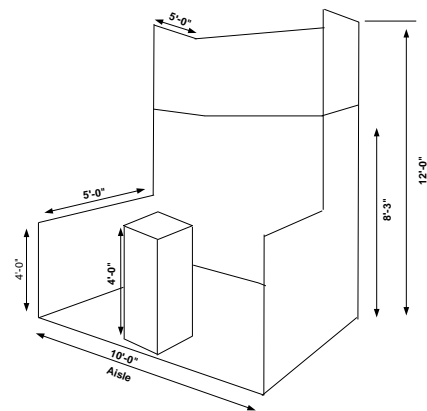

Exhibit Regulations

2017 SPE Canada Unconventional Resources Conference & 2017 SPE Canada Heavy Oil Technical Conference

Where two (2) peninsula booths share a common back wall (also known as Split Island Booths), **the maximum height is 16 feet in all areas of the booth, including the back wall.**

SPE does not permit a peninsula booth to back up to linear booths (also known as end-cap booths).

An 8-foot drape is supplied to separate booths. The portion of the booth from the 8-foot drape to the maximum booth height of 16 feet must be finished.

Exhibitor must leave room for common wall pipe and drape (if applicable) to be shared between their booth and the booth sharing the common wall. Booth should not be set so that the plate for the pipe and drape is completely in a neighboring booth.

Hanging signs will **ONLY** be permitted over peninsula and/or split island booths that are 20'x30' (600') or larger. The maximum height of hanging signs is 25' to the top of the sign (if ceiling height allows). Ceiling height is 29'6" to truss.

Double-sided signs, logos and graphics shall be set back ten feet (10') (3.05m) from the common wall of the exhibit space.

3.1.4 Walk-Thru Booths

A Walk Thru Booth is any booth 20'x20' or larger that backs up to another walk-through or peninsula booth.

The maximum height of a Walk-Thru Booth is 16 feet.

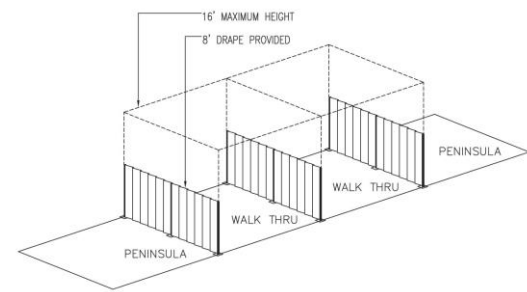

An 8-foot drape is supplied to separate booths. The portion of the booth from the 8-foot drape to the maximum booth height of 16 feet must be finished.

Exhibitor must leave room for common wall pipe and drape (if applicable) to be shared between booths; booth should not be set so that the plate for the pipe and drape is completely in a neighboring booth.

Hanging signs will **ONLY** be permitted over peninsula, split island and walk-thru booths that are 20'x30' (600') or larger. The maximum height of hanging signs is 25' to the top of the sign (if ceiling height allows). Ceiling height is 29'6" to truss.

Double-sided signs, logos and graphics shall be set back ten feet (10') (3.05m) from the common wall of the exhibit space.

3.1.5 Island Booth

An Island Booth is any exhibit 20'x20' or larger and is surrounded by aisles on four sides.

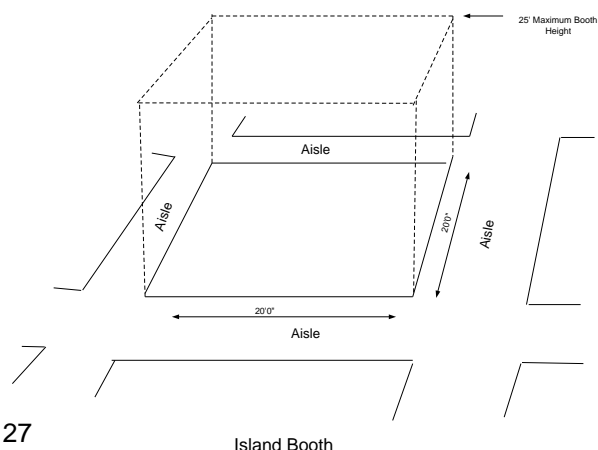

Exhibit Regulations

2017 SPE Canada Unconventional Resources Conference & 2017 SPE Canada Heavy Oil Technical Conference

The maximum height of an island booth is 25 feet in all areas of the booth. Certain physical limitations of the BMO Centre at Stampede Park may prohibit the maximum 25-foot booth height. Exhibitors should refer to the floor plan to specific height limitations.

Exceptions to the 25-foot maximum booth height may be extended to physical equipment that exceeds the maximum height restrictions. This does not include the physical exhibit structure. Exceptions are at the discretion of SPE.

Hanging signs are permitted over island booths. The maximum height of hanging signs is 25' to the top of the sign (if ceiling height allows). Ceiling height is 29'6" to truss.

PLEASE NOTE: Due to Building Inspector ruling, hanging signs in the low ceiling area of The BMO Centre at Stampede Park are NOT permitted.

3.2 Weight Restrictions

Display and/or operation of any heavy equipment must be subject to the floor loading limits of the exhibition area. The maximum weight capacity for Hall D is 250 lb/ft² (1220.6 kg/m²).

3.3 Multi-Level Booths

All multi-level (double-decker) booths require certification by a registered engineer and floor plans must be submitted to SPE Show Management by 4 January, 2017 in order to obtain Fire Marshal approval.

Construction of multi-level booths must conform to all applicable local codes, (specifically NFPA 101 Life Safety Code 2000 ed) regarding access, egress and fire safety equipment. Multi-level booths require a minimum of 20 foot ceiling height. Ceiling height is 29'6" to truss.

If your multi-level booth uses the exact same design as 2016, the Fire Marshal will accept a notarized letter on company letterhead to that affect, in lieu of re-submitting the design specs.

The BMO Centre at Stampede Park has specific regulations for an island multi-level booth. Please contact Debbie Weaver for details, dweaver@spe.org. The BMO Centre at Stampede Park is not responsible for these exhibits obstructing or being affected by building air and lighting systems. All booths should have at least (1)2A10BC fire extinguisher and a portable fire detector.

Multi-Level Exhibits and Drawings submitted for review must meet the following requirements:

1. Meet or exceed the requirements of NFPA 101 Life Safety Code 2000 ed.
2. Drawings must bear a current registered design professional's stamp (architect, structural engineer, fire protection engineer, etc.). **Expired licenses are unacceptable.** The professional stamp shall include the state of certification, name of the registered design professional; his/her license number, signature, registered engineering firm name and firm number.
3. Drawings must be submitted in English.
4. Metric units of measurement are acceptable but they must identify what unit of measurement is being used

Exhibit Regulations

2017 SPE Canada Unconventional Resources Conference & 2017 SPE Canada Heavy Oil Technical Conference

5. For detailed rules and regulations for multi-deck structures, please contact Debbie Weaver at dweaver@spe.org.
6. Stairway widths shall be:
 - a. A minimum of 36 inches where the occupant load of the upper level is less than 50
 - b. A minimum of 44 inches where the occupant load of the upper level is 50 or more
 - c. Occupant loads shall be stated on the plan
7. Handrails shall not be less than 34 inches and not more than 38 inches above the surface of the tread.
8. Handrails are required on both sides. A sign must be placed at the bottom of the stairs stating "Please Use Caution and Hold the Handrail".
9. Spiral stairways shall be permitted in accordance with section 7.2.2.2.3.3 of NFPA 101, 2000 ed., such that:
 - a. Occupant load does not serve more than 3
 - b. Clear width of stairs is not less than 26 inches
 - c. Handrails shall be provided on both sides
10. Guards shall:
 - a. Not be less than 42 inches high
 - b. Open guards shall have intermediate rails or an ornamental pattern to prevent a 4 inch diameter sphere to pass through any opening up to a height of 34 inches
11. Battery-operated smoke detectors shall be installed on a smooth surface under the first level ceiling and spaced no more than 30 feet apart if applicable and installed on the upper floor level with a covered ceiling
12. Hard covered ceilings shall have a smoke detector installed and if fabric/textile is used to cover the upper deck area, it must be flame resistant.
13. One portable fire extinguisher, minimum 2A 10B:C with current maintenance tags shall be provided at each level of the exhibit
14. Live load for the upper level should be at least 125 pounds per square feet.
15. **Any stationary units** (container or other units) using the upper areas as a deck must submit plans.
16. **All submittals shall be received 60 - 90 days prior to the event date by email to Debbie Weaver at dweaver@spe.org or on a multi-media storage device (flash drive or similar device).**

3.4 Hanging Signs & Graphics Guidelines

Exhibit Regulations

2017 SPE Canada Unconventional Resources Conference & 2017 SPE Canada Heavy Oil Technical Conference

PLEASE NOTE: Due to Building Inspector ruling, hanging signs in the low ceiling area of the BMO Centre at Stampede Park are NOT permitted.

- Hanging signs are permitted in peninsula and walk-thru booths with dimensions of 20'x30' (600') or larger, and island booths with dimensions of 20'x20' (400') or larger.
- Hanging signs are NOT permitted in standard/linear booths; and peninsula, split island, and walk thru booths with dimensions less than 20'x30' (600').
- The maximum allowable height for hanging signs is 25' measured from the floor to the top of the sign, no exceptions. If trusses needed for lighting of the sign are required to go higher than 25', Exhibitor must get authorization from SPE.
- Certain physical limitations of exhibit facility may prohibit the maximum 25-foot allowable height. Exhibitors should refer to the floor plan for specific height limitations. The maximum allowable height of hanging signs is also dependent on the ceiling load limits.
- Exhibitors are responsible for notifying SPE and/or GES if they are planning on hanging signs in their exhibit booth design. Exhibitors must send this written notification by 4 January, 2017. If written notification is not received, SPE and/or GES cannot guarantee the hanging of the sign or graphic. Exhibitors will not be granted an extension to the published move-in schedule for delays caused by the installation of hanging signs or graphics.
- Any lighting associated with a hanging sign must be integral to the sign and no spotlighting is allowed. **All lighting of signs must be within the perimeter of the booth dimensions and cannot extend into the aisles or be attached to the building outside the confines of the booth.**
- All sides of hanging signs and graphics must be covered or finished in such a manner as not to detract from those booths behind it. All hanging signs and graphics, regardless of size, should be constructed of lightweight flameproof materials.
- Any signage extending higher than the external booth wall and visible to those viewing booths in the aisles behind it must remain stationary with the rear of the sign covered and/or finished in such a manner as not to detract from those booths behind it. All materials must be contained within the contracted booth space.
- Any double-sided or unfinished graphics in a split-island (peninsula) or walk-through booth must be set back 10 feet from the common wall.
- Facility regulations state that no signs will be allowed to hang from any electrical fixtures, raceways, water/gas/air/fire protection piping, supports or hangers. Permanent facility graphics, signs or displays may not be blocked in any manner.
- All overhead hanging signs must be assembled, installed, removed and disassembled by GES. Exhibitors, display companies and/or I&D representatives may supervise their respective rigging activities, but will not be allowed to assemble/disassemble or install/remove rigging.

Exhibit Regulations

2017 SPE Canada Unconventional Resources Conference & 2017 SPE Canada Heavy Oil Technical Conference

- All rigging must conform to show rules, regulations and exhibit facility limitations. Hanging anchor points must be pre-fabricated and ready to use. If any hang point supports over 250 pounds, Exhibitor must notify GES immediately for special authorization.
- For hanging signs and graphics, other than banners, Exhibitor must submit a blueprint or drawing to GES with detailed information in order for hanging anchor points to be determined. Electrical signs must be in working order and in accordance with the National Electrical Code. Electrical Service requirements must be ordered in advance through the Official Electrical Contractor.
- Exhibitor is responsible for providing GES with a placement diagram of the hanging sign including the number of feet from each side of the exhibit space that the sign is to be placed. The ceiling structure and relation to the support beams may require Exhibitor's sign to be moved from the requested location.
- Exhibitor is also responsible for providing GES with the type of sign (cloth, metal, wood, other), shape (square, triangle, rectangle, other), size (height, length, width), and weight.
- Overhead hanging signs are to be sent in separate containers directly to GES. All containers must arrive no later than one week prior to the first Exhibitor move-in day. Should an Exhibitor not arrange for an advance shipment of the hanging signs, Exhibitor must notify GES. If these procedures are not followed, SPE and GES cannot guarantee the hanging of the sign. Exhibitors will not be granted an extension to the published move-in schedule for the delays caused by the installation of hanging signs.
- All hanging signs are subject to SPE inspection and may require on-site modification.

4 Build up and Breakdown

4.1 Construction

- **No open-toe shoes are permitted on the exhibit floor during move-in and move-out.**
- Designated "NO FREIGHT" aisles must be maintained clear of crates and exhibit materials during move-in and move-out. These aisles are required for emergency access throughout the exhibit areas and to expedite freight and empty crate moving.
- All exhibit displays should be designed and erected in a manner that will withstand normal contact or vibration caused by neighboring Exhibitors, hall laborers or installation/dismantling equipment such as forklifts. Displays should also be able to withstand moderate wind effects that may occur in the exhibit hall when freight doors are open. Exhibitors should refer to local building codes that regulate temporary structures.
- The penetration of floors, walls, ceilings, or trim will not be permitted; neither may any holes be drilled in any portion of the facility. Displays must be freestanding and not rely on any part of the exhibit facility other than the floor for support.

Exhibit Regulations

2017 SPE Canada Unconventional Resources Conference & 2017 SPE Canada Heavy Oil Technical Conference

- Exhibitors should ensure that any display fixtures such as tables, racks or shelves are designed and installed properly to support the product or marketing materials to be displayed upon them.

4.2 Electrical

- Column or wall outlets **may not** be used in the facility for direct connection by anyone other than employees of the Official Electrical Contractor.
- **Exhibitors are strictly prohibited from installing their own electrical wiring.** All electrical, water, gas, etc. connections must be handled by the Official Electrical Contractor. Should any electrical work be located that was not installed by the Official Electrical Contractor, SPE Show Management will have the wiring disconnected and removed at the Exhibitor's expense. **No exceptions are permitted.**
- If an Exhibitor (or their EAC) ignores or fails to comply with a verbal/written warning by OTC Show Management with a repeated offense, the contracted Exhibitor will lose five (5) priority points. If Exhibitor (or their EAC) is cited for more than 2 offenses, Exhibitor will forfeit thirty (30) priority points. Contracted Exhibitors are responsible for the actions of their co-Exhibitors and their EACs. [SPE reserves the right to escort offending personnel out of the event for the duration of the event](#)

PLEASE NOTE: The BMO Centre at Stampede Park requires the use of 14 gauge electric wire, or greater, with grounded conducting cable. The use of flat cables is recommended within booths.

4.3 Decorating

- Any portion of a display that extends above or beyond that of the booth adjoining to the rear or side must be finished with paint or drape at the Exhibitor's expense. Any portion of an Exhibitor's booth facing an aisle must be finished.
- **BOOTH DRAPING (MASKING):** SPE regulations require covering (finished and/or draping) on the open side of the booth in a corner location, if materials are stored behind the display or if grid work and/or electrical cords are exposed to public viewing. Exposed parts of displays (including backs) must be completely finished so that they are not objectionable to other Exhibitors, delegates or SPE Management and are in keeping with the professional appearance on the exhibition floor. Any booth draping (masking) required for either or both sides (or back) of a booth by the end of Move-in on the Saturday before opening day of the Event will be ordered from the official contractor at the expense of the Exhibitor.
- Drip pans and scrap buckets should be provided for operating machinery to prevent lubricants, paints, etc., from staining the floor causing a slippage hazard.
- Painting (or spray paint) inside the facility is typically not permitted due to fumes and vapors. Some exceptions are made if no odor or toxic properties are present; however, permission from show management is mandatory and a request for permission should be sent to Debbie Weaver no later than 5 September, 2016.

Exhibit Regulations

2017 SPE Canada Unconventional Resources Conference & 2017 SPE Canada Heavy Oil Technical Conference

- Exhibitors are liable for any damage they cause (or third party authorized by them) to the walls, floors, columns, doors, windows, etc., during the installation, operating and dismantling of their exhibits.

4.4 Lighting

- Exhibitors must adhere to the following suggested minimum guidelines when determining booth lighting:
 - No lighting, fixtures, lighting trusses, or overhead lighting are allowed outside the boundaries of the exhibit space. Exhibitors intending to use hanging light systems must submit drawings to exhibition management for approval.
 - Any lighting associated with a hanging sign must be integral to the sign and no spotlighting is allowed. **All lighting of signs must be within the perimeter of the booth dimensions and cannot extend into the aisles or be attached to the building outside the confines of the booth.**
 - Lighting, including gobos, must be directed to the inner confines of the booth space. Lighting should not project onto other exhibits or exhibition aisles.
 - Lighting which is potentially harmful, such as lasers or ultraviolet lighting, must comply with facility rules and be approved in writing by exhibition management.
 - Lighting that spins, rotates, pulsates, and other specialized lighting effects must be in good taste and not interfere with neighboring Exhibitors or otherwise detract from the general atmosphere of the event.
 - Currently some convention facilities are not allowing quartz halogen lighting fixtures in exhibits due to potential fire hazards. Check with exhibition management.
 - Reduced lighting for theater areas must be approved by the exhibition organizer, the utility provider, and the exhibit facility.

4.5 Carpeting

- The use of carpeting or other professional floor covering **is required** by each Exhibitor, if the exhibition hall is **not carpeted**. These floor coverings must not be sealed to the floors in such a manner as to injure the floor or be so installed as to be a hazard to public safety or as to endanger the public. Exhibitors are responsible for the final condition of the floor in their space. The edges of raised flooring may be inclined, providing the slope is gradual and gentle. Exhibitors are urged to simplify access for disabled persons by providing a ramp of at least 3.5 feet wide set in place at right angles to the aisle in accordance with the **Americans with Disabilities Act (ADA)**. See **Section 5.5**
- If an exhibitor sets his booth without floor covering, carpet will be ordered at the exhibitor's expense.

Exhibit Regulations

2017 SPE Canada Unconventional Resources Conference & 2017 SPE Canada Heavy Oil Technical Conference

4.6 Installation/Dismantle Schedule

Exhibitors must comply with the published installation and dismantling schedules and procedures as outlined in the Exhibitor Services Manual. Requests for alterations to these schedules must be submitted to SPE in writing for approval.

4.6.1 After Hours Work Permits

SPE recognizes that, in critical situations, it may be necessary for an Exhibitor to work beyond the published installation and dismantle scheduled hours. Authorization to work late will be based on the type of work to be done, and the number of people needing access to the Exhibit Hall. Exhibitors should obtain approval from SPE Exhibit Management. For authorization to work late, you must be able to demonstrate that construction of your exhibit cannot be completed during scheduled hours. For safety and security reasons, work late authorizations will be granted only when conditions impact a company's ability to complete construction of their exhibit.

4.6.2 Unattended Freight

Exhibitor or its EAC is encouraged to remain with their freight during move-out until it is picked up from the exhibit hall by the Official Freight Contractor. **Show Management is not responsible for loss of unattended freight. Additional security may be hired at Exhibitor's expense.**

4.7 Booth Inspection Deadline (No-Show Ruling)

- The installation of all exhibits must be complete by 1700 on Tuesday, 14 February. No installation will be allowed after 1700 on Tuesday, 14 February without written approval by SPE Show Management. Approval of late installation requests is solely at the discretion of SPE Show Management and must be in writing.
- Exhibitors must submit written notification for installations that will not begin until after 1700 on Tuesday, 14 February, for SPE Show Management approval. Approval of late installation requests is at the discretion of SPE.
- Should an exhibit space remain vacant after 1700 on Tuesday, 14 February, and arrangements for exhibit services (carpet, electricity, freight delivery, etc.) have been ordered and verified, SPE will assume the Exhibitor will be late, but will arrive.
- Should an exhibit space remain vacant after 1700 on Tuesday, 14 February, with no arrangements for exhibit services ordered, and SPE has not been notified of a Saturday afternoon installation, SPE will assume the Exhibitor will NOT be exhibiting and will make this area into a carpeted lounge or attempt to resell it. SPE also reserves the right to resell the cancelled space and the contract will become **null and void**. (Should an Exhibitor arrive after these steps have been taken, the Exhibitor will be responsible for costs incurred by SPE). There will be no refunds due to an Exhibitor who fails to utilize its contracted space and the Exhibitor will remain responsible for any outstanding balances due.

Exhibit Regulations

2017 SPE Canada Unconventional Resources Conference & 2017 SPE Canada Heavy Oil Technical Conference

4.8 Early Tear Down

Should an Exhibitor begin to dismantle or vacate its exhibit space before the official close of the show, the Exhibitor will be penalized five (5) points, from their priority point total, if applicable and/or be subject to loss of their right to participate in future SPE events. Floor managers/Exhibit Manager will report the names of companies in violation of this rule to Show Management. Emails will be sent post-show informing Exhibitors of their penalty.

Exhibitors are responsible for notifying their booth personnel of this regulation. In fairness to all Exhibitors, this regulation will be uniformly enforced to all SPE Exhibitors.

5 Health and Safety

5.1 General Safety Procedures

- **No open-toe shoes are permitted on the exhibit floor during move-in and move-out.**
- The use of bicycles, roller skates, roller blades and/or motorized or manually operated scooters (including Segway's and hover boards) is strictly prohibited in the exhibit areas at all times by any Exhibitor or Exhibitor Appointed Contractor (EAC). Only current **ADA** approved equipment will be authorized.

5.2 Alcohol

5.2.1 Consumption of Alcohol

SPE recognizes the legitimate serving of alcoholic beverages in the process of conducting business and social activities. We also recognize that the use and consumption of alcohol carries with it the requirement for exhibitors to serve alcoholic beverages responsibly and in keeping with our professional code of ethics and conduct. We strongly oppose the abuse and misuse of alcohol. Please adhere to the following regulations when serving alcohol in your booth space at SPE events.

- On days when a reception is scheduled for the end of the day, exhibitors may begin serving alcohol 30 minutes prior to the beginning of the reception.
- On days when no reception is scheduled, exhibitors may begin serving alcohol 1 hour prior to the end of the technical sessions.

5.3 Fire and Safety Procedures

5.3.1 Aisles

- Designated "NO FREIGHT" aisles must be maintained clear of crates and exhibit materials during move-in and move-out. These aisles are required for emergency access throughout the exhibit areas and to expedite freight and empty crate moving.
- Equipment must be arranged so that show visitors do not block the aisle while examining equipment or watching demonstrations. Strolling entertainment or moving advertisements outside of Exhibitor's exhibit space is prohibited. Normal aisle traffic cannot be blocked at any time. Should

Exhibit Regulations

2017 SPE Canada Unconventional Resources Conference & 2017 SPE Canada Heavy Oil Technical Conference

TV/plasma/LCD screens placed on the outside walls or outer edge of an exhibit result in blockage of traffic, show management reserves the right to ask that the screen in question be turned off.

- No Exhibitor shall in any manner obstruct an exit, aisle, restroom or easement at any time. In all cases, exits and fire connections must be clearly identifiable. The Fire Marshal shall have the final ruling on this matter.
- Drip pans and scrap buckets should be provided for operating machinery to prevent lubricants, paints, etc., from staining the floor causing a slippage hazard.

5.3.2 Fire Regulations

The regulations of the city Fire Department must be followed, and all exhibits may be subject to Fire Department inspection.

- All decorative materials including drapes, signs, banners, acoustical treatments, table coverings, etc., must be noncombustible or effectively treated with an approved fire retardant chemical.
- All canopies, ceilings, or other overhead construction for booths or exhibits must be of non-combustible materials.
- Display and/or operation of any heavy equipment must be subject to the floor loading limits of the exhibit area.
- Any special effects, decorations, displays, or operating equipment of any kind of questionable nature must be approved before being installed.
- The use of any flammable liquids, gases or solids and the use of compressed gases are not permitted.
- Heat-producing appliances employing open flames, high heat, lighting effects, etc., as part of an exhibit shall not be operated unless special approval has been obtained.
- All operating electrical, plumbing and heating devices shall be installed in compliance with the requirements of the City Municipal Code. The required permits shall be obtained before such installations are made, and all installations shall meet with the approval of the inspecting authority.
- Fire hose reels and cabinets must be readily accessible and cannot be obstructed in any manner whatsoever.
- **STORAGE:** Fire regulations in most exhibit facilities prohibit storing product, literature, empty packing containers or packing materials behind back drapes or under draped tables. In most cases, however, Exhibitors may store a limited supply of literature or product appropriately within the booth area, as long as these items do not impede access to utility services, create a safety problem or look unsightly.

Exhibit Regulations

2017 SPE Canada Unconventional Resources Conference & 2017 SPE Canada Heavy Oil Technical Conference

5.3.3 Indoor Display of Vehicles

The indoor exhibiting of motorized vehicles or other equipment involving the use of flammable liquids shall be subject to specific regulations. Gas tanks must not contain more than ¼ tank of fuel and must be sealed, locked, and all battery cables must be disconnected. Ignition keys must be removed and at display location. **Exhibitor must notify SPE Management at least 72 hours prior to bringing a vehicle on show site.**

5.4 Security

SPE will provide appropriate security in order to ensure the safety of its attendees and Exhibitors. **SPE assumes no responsibility for loss, damage or theft incurred to any exhibit or property of the Exhibitor.** SPE recommends that Exhibitors consider the benefit of securing individual security guards for the exhibit. Exhibitor booth security may be ordered through the facility. Unauthorized persons will not be permitted to enter or remain in the exhibit areas after closing hours; however, certain authorized persons may have access to the exhibit areas at any time.

6 Utilities and Services

6.1 Electrical

- Column or wall outlets **may not** be used in the facility for direct connection by anyone other than employees of the Official Electrical Contractor.
- **Exhibitors are strictly prohibited from installing their own electrical wiring.** All electrical, water, gas, etc. connections must be handled by the Official Electrical Contractor. Should any electrical work be located that was not installed by the Official Electrical Contractor, SPE Show Management will have the wiring disconnected and removed at the Exhibitor's expense. **No exceptions are permitted.**
- If an Exhibitor (or their EAC) ignores or fails to comply with a verbal/written warning by OTC Show Management with a repeated offense, the contracted Exhibitor will lose five (5) priority points. If Exhibitor (or their EAC) is cited for more than 2 offenses, Exhibitor will forfeit thirty (30) priority points. Contracted Exhibitors are responsible for the actions of their co-Exhibitors and their EACs. OTC reserves the right to escort offending personnel out of the event for the duration of the event.

PLEASE NOTE: The BMO Centre at Stampede Park requires the use of 14 gauge electric wire, or greater, with grounded conducting cable. The use of flat cables is recommended within booths.

6.2 Catering

Arrangements for all food and beverages must be purchased through the Official Caterer. This regulation pertains both to food and beverage for staff consumption as well as to food and beverage distributed from booth during show hours. Beverages include alcoholic beverages, soft drinks, coffee, bottled water, etc. Exhibitors found in violation of this ruling are subject to corkage fees established by the Official Caterer and/or may lose their right to participate in future SPE exhibitions.

Exhibit Regulations

2017 SPE Canada Unconventional Resources Conference & 2017 SPE Canada Heavy Oil Technical Conference

6.3 Cleaning and Waste Disposal

CLEANING AND DISPOSAL OF USED/EXCESS MATERIALS: Each Exhibitor must keep its exhibit clean and properly dispose of all refuse. Exhibitor and their appointed contractors are responsible for the removal of Visqueen covering by the end of move in on Tuesday. If exhibitor's booth remains covered or cordoned off on Wednesday morning, any vacuuming necessary on Wednesday morning will be at the expense of the exhibitor. In addition, exhibitor will be responsible for the disposal of the Visqueen and for vacuuming all aisles around their booth. Failure to comply with this regulation will result in the loss of 5 priority points for the contracted exhibitor. All used or leftover materials resulting from delivery, installation and removal activities of the Exhibitor shall be disposed of at the Exhibitor's expense. Exhibitors are responsible for disposing of the refuse generated during the show hours or must contract with facility to have refuse removed during show hours. **Under no circumstances are Exhibitors permitted to dispose of refuse in the aisles prior to or during show hours.** In addition, Exhibitors are responsible for the removal and disposal of carpeting, padding, and/or professional flooring, not ordered from GES, and utilized in their space. Should any of these items remain within the exhibit space after dismantling, these items will be disposed of by GES at the Exhibitor's expense.

6.4 Internet

All wireless access points not authorized by facility are prohibited.

7 Character of Exhibit

The SPE Canada Unconventional Resources Conference & SPE Canada Heavy Oil Technical Conference is undertaken primarily for the technical education of their members. To provide the best possible atmosphere to discuss the technical application of the equipment and services displayed, each Exhibitor agrees as follows:

- To exhibit only products, which it manufactures, represents or distributes, which comprise of materials, equipment, apparatus, systems, services and other component products applicable to advancing the engineering and scientific knowledge and development of energy resources and environment.
- All exhibit displays, images and language are not of a nature that could be considered discriminatory or offensive
- SPE reserves the right to prohibit an exhibit or part of an exhibit, including promotional materials and graphics that in its judgment, could be construed as discriminatory or advocating discrimination on the basis of race, gender, religion, sexual orientation, or national origin.
- To ensure that all staff, including demonstrators, hosts/hostesses, entertainers and other employees and personnel adhere to an appropriate standard of dress for a business setting or function, and standard of behavior suitable for a business environment, in the location where the event is taking place
- Should SPE feel that your booth personnel are infringing on cultural or professional standards in terms of dress or behavior, SPE reserves the right to caution or eject such personnel from the event.

Exhibit Regulations

2017 SPE Canada Unconventional Resources Conference & 2017 SPE Canada Heavy Oil Technical Conference

- No Exhibitor shall assign, sublet, or apportion the whole or any part of the space allotted, nor exhibit therein, nor permit any other person or party to exhibit therein, any other goods, apparatus, etc., not manufactured or distributed by the Exhibitor in the regular course of business except upon prior written consent of SPE Show Management.
- SPE Show Management is sensitive to the time, effort and cost related to the success of the conference by Exhibitors, and therefore, expressly forbids the solicitation of goods and services, distribution of literature, promotional items or souvenirs by anyone other than registered Exhibitors. Anyone observed to be soliciting business in the aisles or other public areas or in another company's booth will be asked to leave immediately. Please report any violations you may observe to Show Management.
- To refrain from the performance of any act that affects a sale of any of the products or services being displayed or that constitutes a necessary step in effecting such sale. The prohibited acts shall include, but are not limited to: (a) the actual sale of products in return for cash, check or other legal tender received at the exhibit; and (b) the execution of contracts or other documents that effect a sale of products or services, whether or not accompanied by receipt of a deposit thereon, for delivery of performance following the Exhibition. Exhibitors may secure names and addresses of persons expressing an interest in the products or services being displayed for the purpose of contacting such person after the Exhibition.
- All exhibits must be manned by at least one company representative during official Show hours specified by SPE. Exhibit space must be maintained in a neat, orderly manner throughout the exhibition, and no dismantling may begin before the official closing hour on the final day of the exhibition. **Early tear down will result in the loss of five (5) priority points for your company, if applicable.**
- Exhibitor personnel have access to the exhibit floor prior to and after show hours. However, exhibit staff is not to enter other booths and should remain only in the vicinity of their own booths. Exhibit staff is not to interact with or photograph any other booths or displays at any time.
- In deference to fellow Exhibitors and to the professional people who constitute the exhibit audience, Exhibitors are specifically prohibited from employing any carnival type attraction, animal or human, or from operating such noise creating devices as bells, horns, or megaphones. Sound or music within a booth is permitted, but must be controlled to a reasonable level, and must not be projected outside the confines of the exhibit booth and should not disrupt the activities of the neighboring Exhibitors. Exhibitors are responsible for obtaining all necessary licenses and permits to use music, photographs or other copyrighted material in the Exhibitor's booth or display. Personnel must be appropriately clad and must remain within the Exhibitor's booth space except when necessarily arriving and leaving the booth or exhibition area.
- Exhibit displays are subject to inspection by SPE and may require modification to meet safety standards. SPE reserves the right to remove any exhibit, at the Exhibitor's expense, if the display does not meet the specifications set forth in the Exhibit Regulations.
- If an Exhibitor (or their EAC) ignores a verbal/written warning by SPE Show Management with a repeated offense, the contracted Exhibitor will lose five (5) priority points, if applicable. If Exhibitor (or their EAC) is cited for more than 2 offenses, Exhibitor will forfeit thirty (30) priority points, if

Exhibit Regulations

2017 SPE Canada Unconventional Resources Conference & 2017 SPE Canada Heavy Oil Technical Conference

applicable. Contracted Exhibitors are responsible for the actions of their co-Exhibitors and their EACs.

- SPE's ruling on such matters will be final

7.1 Good Neighbor Policy

Any Exhibitor using audio/video content in its booth for the purpose of demonstrating equipment or services agrees that such content shall be appropriate for a general audience, and agrees to refrain from using content that may be considered offensive to such an audience. In the event of a complaint from any person regarding the content or noise level by an Exhibitor, SPE will investigate the complaint. Should SPE determine the content to be offensive or in excess of appropriate noise levels, Exhibitor agrees to cease using such content or noise making device. Repeated violations of this policy can, at SPE's sole discretion, result in expulsion from the show.

7.2 Noise

- **NOISE LEVELS:** Mechanical reproduction of sound or music relating to an exhibit, or noise generated by production demonstrations shall be kept at a sufficiently low volume so as not to project beyond the confines of the Exhibitor's booth and should not disrupt the activities of the neighboring Exhibitors. Speakers and other sound devices should be positioned so as to direct sound into the booth rather than the aisles. Exhibitors employing a band in their booth may not connect them to an amplifying system.
- SPE reserves the right to impose limitation on noise levels and any method of operation, which becomes objectionable. Any sound that consistently exceeds 80 decibels measured at the edge of an Exhibitor's booth is considered objectionable. However, continuous, monotone sound less than 80 decibels can also be a problem. Show Management reserves the right to determine at what point sound constitutes interference with others and must be discontinued.
- Should Exhibit Management receive complaints regarding the level of sound, the Exhibitor will be asked to reduce the audible level. If the Exhibitor does not comply and/or the complaints continue, the Exhibitor will be notified that the sound or music performance must be discontinued or may be subject to dismissal from the exhibit floor.

7.3 Copyright Regulations

Exhibitors shall not display, perform, or otherwise reproduce any Copyrighted Work of another without the express written consent of the copyright owner. The term "Copyrighted Work" includes literary works, musical compositions and performances, phonographs, audiotapes, videotapes, motion pictures, photographs, graphics, and all other works for which U.S. Copyright Law affords protection. More specifically, Exhibitor shall not display, perform, or otherwise reproduce, or cause to permit to be displayed, performed, or otherwise reproduced, any copyrighted musical composition or performance of another at the Exhibition without the copyright owner's express written consent. This includes the reproduction of any radio or television broadcasts, audiotapes, videotapes, and/or motion pictures that include, in whole or in part, the music composition(s) of any other party.

Exhibit Regulations

2017 SPE Canada Unconventional Resources Conference & 2017 SPE Canada Heavy Oil Technical Conference

7.4 Hospitality Functions

- Exhibitors hosting off-site hospitality functions are prohibited from holding those activities during official event hours or official events as described below, without prior written approval from SPE Management:

Official Show Hours: Wednesday, 15 February, 2017 from 0730-1800 hours and Thursday, 16 February, 2017 from 0730 to 1530 hours

Official Show Events:

Wednesday, 15 February		Thursday, 16 February	
Registration	0700 - 1700	Registration	0730 - 1530
Exhibition	0730 – 1800	Exhibition	0730 – 1530
Breakfast	0730 - 0830	Breakfast	0730 – 0830
Coffee Break	1000 – 1030	Coffee Break	1000 – 1030
Lunch	1200 – 1330	Lunch	1200 – 1330
Coffee Break	1500 – 1530	Coffee Break	1500 – 1530
Welcome Reception	1630 – 1800	Exhibitor Move-Out	1530 - 2000

Only Exhibitors in good standing are permitted to host a hospitality function in an official Event hotel. (All requests for a hospitality suite or public function space must be made through SPE). If an exhibitor should cancel or not occupy the exhibit space during official Event hours, SPE reserves the right to notify the hotel to cancel any hospitality space and/or hotel guest rooms under that company's name. Exhibitor shall remain liable for the payments made to the hotel. Any Exhibitor or its division or subsidiary (whether or not that division is contracting for space in the Event), conducting any function in direct competition with the official Event hours, or at any time during the official Event days, will forfeit the rights of the exhibiting company to obtain hospitality suites and/or function space over the official Event days the next year and will forfeit 30 Priority Points, if applicable. Under no circumstances will Exhibitor or any division or subsidiary be allowed to provide mass transportation of attendees from facility during the official Event hours.

8 Insurance

Insurance for fire, public liability and theft must be taken out by each Exhibitor at its own expense. The insurance is to cover the full period of occupancy of the premises by the Exhibitor, its agents and employees.

9 Employment and Venue Regulations

9.1 Smoking Policy

The BMO Centre at Stampede Park is a non-smoking facility. Smoking is prohibited in all areas of the BMO Centre at Stampede Park except in Designated Smoking Areas.

Exhibit Regulations

2017 SPE Canada Unconventional Resources Conference & 2017 SPE Canada Heavy Oil Technical Conference

9.2 Employment of Labor/ Union Jurisdiction

Exhibitor shall abide by and observe all federal, state and local laws, codes, ordinances, rules and regulations, and all rules and regulations of facility (including any union labor work rules). (Please refer to the Union Labor information provided in the Exhibitor Services Manual.)

9.3 Age Restrictions to Exhibit Areas

No one under the age of 18 is permitted in the Exhibit Areas during move-in or move-out.

No one under the age of 15 is permitted in the Exhibit Areas during official show hours.

9.4 Parking

Any vehicle parked on the street or in designated no parking zones or designated fire lanes will be towed to a location designated by exhibit facility at the owner's expense.

The BMO Centre at Stampede Park imposes a parking fee on all vehicles entering the property on event days, including exhibitors and contractors.

10 Photography, Recording and Advertising

10.1 Photography/Video/Audio Recording Regulations

SPE is organized and operated exclusively to promote and further advance scientific and technical knowledge of offshore resources and environmental matters. To maintain the unparalleled technological experience, SPE must enforce a photography and videography policy which will protect the leading-edge technology showcased at the event.

- The following guidelines apply for attendees, exhibiting personnel and exhibitor-appointed photographers at the Society of Petroleum Engineers Conference.
- No audio or video recording or still photography may occur without SPE's permission.
- Attendees, exhibiting personnel and exhibitor-appointed photographers are prohibited from shooting video or photos anywhere in the sessions and the indoor and outdoor exhibition areas. If you see any unauthorized persons who are using cameras of any sort (including camera phones) in the sessions or indoor and outdoor exhibition areas, please contact Exhibit Management.
- Exhibitors **are** permitted to shoot video or take photographs under the following guidelines:
 - In their own booth for promotional use at any time the exhibition is open, without seeking SPE's permission.
 - At their company press conference held in the SPE press conference room.

Exhibit Regulations

2017 SPE Canada Unconventional Resources Conference & 2017 SPE Canada Heavy Oil Technical Conference

- By using outside photographers and video crews. Outside photographers and video crews are required to obtain permission from SPE Press Room to shoot photos or video of the exhibition.
- Outside photographers and video crews do not qualify for press badges.
- Outside video crews or photographer must use an Exhibitor-Appointed Contractor badge.
- Exhibitors are responsible for supervising the activities of outside video crews and photographers so that they comply with SPE guidelines.
- Exhibitors **are not** permitted to shoot anywhere else on the SPE exhibition floor or anywhere else throughout the conference.
 - When shooting photography or video in their own booth, no other Exhibitor's booth may appear in the shot. SPE Press Room staff can provide overall shots of the exhibition or other aspects of SPE if needed. Please contact the SPE press office at media@SPENet.org.
 - After-hours photography or video are not permitted without making arrangements in advance with SPE exhibit staff.

Exhibitors are responsible for all their company personnel and as such are responsible for communicating these Exhibit Regulations as well as all rules to their employees.

Exhibitor Staff Penalties for Violating the SPE Photography Policy

- **First Warning:** Exhibitor staff will receive a verbal warning about the policy from SPE Staff. They will receive a notation on their exhibitor badge indicating that they have received an initial verbal warning.

SPE will also inform the exhibiting company's primary contact about the incident and the consequences for a second offense.
- **Second Warning:** Exhibitor staff badge will be confiscated, and the exhibitor staff person will be escorted off the premises by SPE Staff and/or security personnel.

10.2 Marketing and Advertising

- Samples, souvenirs and advertising material may be distributed by the Exhibitor only from within its booth. Balloons (including helium) and stickers are prohibited in the BMO Centre at Stampede Park. (Handouts with gummed backing that adhere or cause adhesion are considered stickers.) Cost of repair due to damage to the facility caused by stickers obtained from an Exhibitor will be the responsibility of that Exhibitor.
- **DISTRIBUTION OF PUBLICATIONS:** Publications/brochures may only be distributed from the Exhibitor's booth – **no distribution is permitted from the aisles of the Exhibition Hall, the registration area, or anywhere in venue nor may publications or brochures be left on the table in the foyer or any conference area.** Failure to comply with this regulation will result in the loss of 5 priority points, if applicable, for the exhibiting company. Publication Cubicles may be rented by

Exhibit Regulations

2017 SPE Canada Unconventional Resources Conference & 2017 SPE Canada Heavy Oil Technical Conference

companies for their industry related publications. Brochures other than those assigned to the company renting the cubicle will be removed and destroyed. This regulation pertains to pre-show as well as during the exhibition.

10.3 Solicitation

Exhibitors who have purchased a sponsorship may not distribute their collateral materials to other Exhibitor's booths. SPE is responsible for the production of signage and the distribution of items associated with an Exhibitor's sponsorship. This regulation applies to pre-show as well as during the exhibition.

10.4 Market Research and Surveys

Any Exhibitor wishing to conduct market research or surveys during the event must adhere to the following procedures. Surveys and questionnaires must be submitted for approval to the SPE Exhibits Manager no later than sixty (60) days prior to the event.

All surveys/questionnaires must be conducted within the confines of the Exhibitor's booth. At no time may exhibit personnel leave their booth to encourage participation or to survey/question attendees.

Market research companies must identify the names of the clients for whom they are conducting research. Survey documents and any publication or results may not include the name of the conference or make any reference to the event which might cause respondents or readers to believe that SPE is endorsing, approving, or involved with the research. Exhibitors who violate these guidelines may jeopardize their earned priority points and future participation in SPE.

10.5 Registration Lists/Lead Retrieval

Exhibitor understands and agrees that in exchange for its payment, it will receive solely the right to use the exhibit space. The information collected from any purchased registration lists (if applicable) is for the sole use of the company or business organization that collects it. Exhibitor understands and agrees that (i) under the terms of its license, it may not attempt to develop a compilation of attendees and/or other participants of the Event by exchanging any lead information collected at the Event with other attendees, exhibitors and/or other participants at the Event or with third parties not associated with SPE and (ii) the compilation of the attendees and/or other participants of the Event is sole property of SPE and that SPE offers that compilation for sale. Exhibitor agrees that it will not use any lead data collected at the Conference to attempt to develop a compilation of attendees and/or participants that would be competitive to, or could be used in lieu of, the compilation that SPE offers for sale.

11 Exhibitor-Appointed Contractors (EAC)

An Exhibitor-Appointed Contractor (EAC) is any person or company other than the designated "official" or "exclusive" contractors that provide a service (supervision, display installation and dismantling, advertising agencies, models, florists, photographers, aquarium supply firms, computer firms, audiovisual firms, etc.) and requires access to the exhibit hall any time during installation or dismantling or show dates.

While full-time employees of exhibiting companies may set up their own exhibits, any local services that may be required beyond what your employees can provide must be performed by Union Labor. Please refer to the Union Labor information provided in the Exhibitor Services Manual.

Exhibit Regulations

2017 SPE Canada Unconventional Resources Conference & 2017 SPE Canada Heavy Oil Technical Conference

11.1 Exhibitor Responsibilities

- Exhibitors are responsible for advising SPE of their hired EAC's company name, contact information, and a description of the service(s) the EAC will be providing for the Exhibitor.

Exhibiting company must complete and submit the **Work Authorization Request Form** no later than **4 January, 2017**. Submittal after this deadline may not allow adequate time to obtain necessary paperwork from the EAC and result in delays on-site.

- Exhibitors are not permitted to obtain official SPE Exhibitor Badges for their appointed EAC personnel. SPE Exhibitor Badges are for exhibiting companies only..
- Exhibitors are ultimately responsible for each of their EAC's with regards to their services provided, adherence to all SPE Exhibit Regulations, union regulations, financial responsibilities for services acquired through SPE Official and Exclusive Contractors, and violations and/or damages that may occur.

11.2 Exhibitor-Appointed Contractor Responsibilities

- EAC's are required to meet specific criteria before they will be permitted access to the exhibition areas. Upon receipt of the Work Authorization Notification Form, SPE will provide each EAC with a packet of important information regarding the EAC Program. Each EAC must complete all information and no exceptions to this program will be authorized.
- Each EAC must complete and return the SPE **Exhibitor-Appointed Contractor Agreement** and submit to SPE by **18 January, 2017**.
- Each EAC (not exhibiting companies) must submit certificates of insurance for Commercial General Liability Insurance, Business Automobile Liability Insurance and Worker's Compensation Insurance.
 - Commercial General Liability coverage must provide \$1,000,000 Combined Single Limit each.
 - Occurrence and \$2,000,000 General Aggregate and \$1,000,000 Products/Completed Operations Aggregate. Commercial General Liability must include Product/Completed Operations Broad Form Commercial General Liability with **NO EXCLUSIONS**.
 - Business Automobile Liability must include all owned, non-owned and hired vehicles with limits of \$1,000,000 Combined Single Limit Bodily Injury and Property Damage Liability.
 - The Worker's Compensation and Employers' Liability Insurance must provide a minimum limit of \$500,000 each Accident; \$1,000,000 Disease - Policy Limit; \$500,000 Disease - each Employee and meet the Statutory Requirements established by the State of Texas.
 - Umbrella Liability is acceptable to meet above minimum requirements.

Exhibit Regulations

2017 SPE Canada Unconventional Resources Conference & 2017 SPE Canada Heavy Oil Technical Conference

- Alert the insurance carrier that the "Certificate Holder" is the Society of Petroleum Engineers Conference, 222 Palisades Creek Drive, Richardson, TX 75080, U.S.A., +1.972.952.9393.

Deadline: 18 January, 2017

- Additional Insured should include the following wording: "Certificate Holder is Additional Insured with respects to General Liability and Automobile Liability coverage".
- Each EAC must provide the name(s) of their key on-site personnel by completing and submitting the Badge Request Form for Exhibitor-Appointed Contractors Form by **18 January, 2017**.
- SPE will prepare a name badge for the EAC's key on-site personnel, which will be available for pick-up at the EAC Check-in Service Desk located on the BMO Centre at Stampede Park dock, which allows the same access as an Exhibitor badge. EAC's are **NOT** authorized to have Exhibitor badges. All other EAC personnel (non-key on-site personnel) must wear a wristband provided by SPE, which allows access only during installation and dismantling.
- Failure to meet specified EAC Program criteria will jeopardize the EAC's ability to obtain work authorization from SPE now and in the future.

11.3 Rules and Regulations Governing Exhibitor-Appointed Contractors

EAC's are strictly prohibited from soliciting business to SPE Exhibitors by using the name Society of Petroleum Engineers, SPE Canada Unconventional Resources Conference, official artwork, or any verbiage/graphic that resembles SPE Canada Unconventional Resources Conference any form or fashion. SPE Show Management reserves the right to prohibit any company, from admittance to the SPE Canada Unconventional Resources Conference, who violates this policy.

1. EAC's will be denied access to the exhibit floor without current proof of insurance coverage in all of the above mentioned categories.
2. Any EAC found working on the show floor without SPE Management authorization will be escorted from the premises and not allowed back on the exhibit floor.
3. EAC's will refrain from placing an undue burden on the Official Contractors, especially by not interfering in any way with the Official Contractor's work.
4. EAC's will NOT solicit business prior to, during or post show whereby solicitation mentions SPE or contains the utilization of the SPE logo or artwork in any form or fashion. This action is strictly prohibited.
5. EAC's will not set up tables on the exhibit floor other than in the space of a client on whose booth they are working. Solicitation from the show floor is prohibited.
6. EAC's will cooperate fully with SPE Show Management and the Official/Exclusive Contractors and will comply with existing union rules and regulations as outlined in the Exhibitor Services Manual.
7. EAC's may not post signs in their client's booths, listing all their services. A sign that says simply "Designed By - - - -" is allowed with the Exhibitor's approval, but must be removed at start of show.

Exhibit Regulations

2017 SPE Canada Unconventional Resources Conference & 2017 SPE Canada Heavy Oil Technical Conference

8. EACs should ensure that crates are emptied and labeled by 1 hr prior to move in end time and that gang boxes, ladders and large equipment are off the floor by move in end time.
9. Photography and videography are prohibited in the exhibit areas without permission from SPE Management. With approval, EACs may photograph only the booth(s) with which they have contractual arrangements. SPE Management is not responsible for any lost or stolen EAC equipment or EAC installed equipment.
10. While aisle carpeting is being installed, jockey boxes, ladders and the EAC's equipment must be removed completely from the exhibit areas, be placed inside the booth being installed, or removed from the exhibit areas.
11. EAC's are NOT allowed in the exhibit area during installation and dismantling without either an SPE-issued wristband or official SPE conference badge. SPE wristbands and official SPE conference badges are non-transferable and must be worn at all times. SPE Wristbands are not valid during show days.
12. EAC's are NOT authorized to have SPE Exhibitor badges.

PLEASE NOTE: An exhibitor may utilize all or a combination of any of these three sources (Official Contractors, Full-Time Employees, Exhibitor Appointed Contractors & union labor) for exhibit installation and dismantling; however, only authorized personnel will be granted access to the exhibition area.

12 SPE Show Management's Discretionary Rights

SPE Show Management reserves the right, at its sole discretion, to withhold approval or to dismiss from the event, any service contractor whose participation in the event may, in the opinion of SPE, lead to strikes, picketing, or other labor action directed at the event, or other disruptions of the event, or other reasonable interference with or inconvenience to the event or any Exhibitors.

Failure to meet any one of the above steps could jeopardize the Exhibitor-Appointed Contractor's ability to obtain work authorization.

13 Amendments

Any and all matters and questions not specifically covered by these exhibit regulations shall be subject to the decision of SPE and may be amended at any time by SPE in the interest of the Exhibition and upon notice thereof shall be binding on the Exhibitors equally with the foregoing in these exhibit regulations.

Submittal after this deadline may not allow adequate time to obtain necessary paperwork from the EAC and result in delays on-site

Exhibit Regulations

2017 SPE Canada Unconventional Resources Conference & 2017 SPE Canada Heavy Oil Technical Conference

Inquiries regarding the SPE Exhibit Regulations should be directed to:

Society of Petroleum Engineers

Barbara Katz – Sr. Exhibits Manager

222 Palisades Creek Drive

Richardson, Texas 75080-2040 U.S.A.

Telephone: +1.972.952.9326

bkatz@spe.org

For complete information on the SPE Canada Unconventional Resources Conference & SPE Canada Heavy Oil Technical Conference, please visit our website(s) at:

URC

<http://www.spe.org/events/en/2017/conference/17urc/homepage.html>

CHOC

<http://www.spe.org/events/en/2017/conference/17choc/homepage.html>