

ASM19

May 9-11, 2019

Metro Toronto Convention Centre, South Building



Exhibitor's Prospectus

ANNUAL SPRING MEETING | **2019**



Table of contents

- Attendance Statistics** 3
- Important Dates and Deadlines and Early Bird Pricing** 4
- Booth Rental Information** 5-6
 - General Information 5
 - Health Canada Regulations 5
 - New Exhibitors 5
 - Cancellation Policy 5
 - Booth Assignment: ASM Loyalty Points System 5
 - Booth Rental – What’s Included 6
 - Booth Rental – What’s NOT Included 6
 - Booth Fees 6
 - Exhibitor Warnings 6
- Move-In/Move Out Information** 7-10
 - Exhibitor Move-In 7
 - Exhibit Floor Dates and Times At-A-Glance 7
 - Protective Footwear Policy 7
 - Vehicle Marshalling 8
 - Exhibitor Move-Out 8
 - Metro Toronto Convention Centre Map 9
 - Loading Dock Access 9
- Exhibitor Registration Information** 11
 - Exhibitor Badge Registration 11
 - Media Relations 11
 - ASM Badge Colours 11
 - Hotel Reservations 11
 - Conference Session Breaks 11
- Official ASM Hotels** 12
- Official Show Services Suppliers** 13
 - Exhibitor Service Centre 13
- Shipping Information** 14
 - Direct Shipments to Show Site 14
 - Shipping Instructions for United States and International Exhibitors 14
 - Shipments to Advance Warehouse 14
- ASM19 Floor Plan** 15
- Rules and Regulations** 16-19
 - Compliance with Terms of Exhibit Space Rental 16
 - Penalties for Violations 16
 - Booth Restrictions 16
 - Health Canada Regulations 17
 - Payment of Booth Space 17
 - Cancellation Policy 17
 - Booth Staffing 17
 - Code of Conduct 17
 - Exhibit Badges 17
 - Direct / Cash Sales / Handover of Goods 17
 - Distribution of Materials, Samples, and / or Food 17
 - Insurance 18
 - Exhibitor Liability 18
 - Security, Responsibility for Loss or Damage 18
 - Electrical Information 18
 - Fire Safety 19
 - Professional Ethics and Standards with Respect to Exhibits 19
 - Disclaimer 19
 - Default by the Ontario Dental Association 19
 - Privacy 19
- Booth Display Guidelines** 20-22
 - Single Standard Regular Booth 20
 - Multiple Booths in a Straight Row/Full Aisle Booths 20
 - Peninsula Booths 21
 - Island Booths 21
 - Hanging Signs, Banners and Trusses 22
 - Motorized Vehicles 22
 - Professional Videotaping/Photography 22
 - Live Demonstrations 22
- Print Advertising Rate Card** 23-24

INVITATION TO EXHIBIT

The Ontario Dental Association invites you to join us for the 152nd Annual Spring Meeting (ASM) taking place at the Metro Toronto Convention Centre: **May 9-11, 2019**.

Now in its **152nd year**, the ASM attracts more than **12,000 attendees** and features **75,000 square feet** of exhibit space and **320+ exhibitors** from across Canada, the United States and internationally.

The ASM has long been one of the largest and most respected dental meetings in North America and continues to be a prominent gathering place for all dental professionals to connect, learn and excel.



Ontario Dental Association
 4 New Street, Toronto, ON M5R 1P6
 Tel: 416-922-3900
 Fax: 416-922-9005
 Toll Free: 800-387-1393

ASM19

May 9-11, 2019
 Metro Toronto Convention Centre
 South Building

Now in its 152nd year, the ASM attracts in excess of 12,000 dental professionals every year from across Canada, the United States and Internationally to learn, network and share best practices. The exhibit floor features more than 675 booths showcasing the latest innovations and solutions in the dental profession.

ASM Attendance Statistics

	2014 ASM	2015 ASM	2016 ASM	2017 ASM	2018 ASM
ODA Dentists	4,029	3,841	3,921	4,232	3,952
ODA Dental Students	229	276	271	375	321
Dentists Out-of-Province	115	114	201	223	176
Guests (Non Practitioner)	181	184	256	207	182
Dental Hygienists	1,796	1,769	1,947	2,054	1,905
Dental Assistants/Office Personnel	2,432	2,396	2,546	2,686	2,427
Dental Technologists	25	20	18	26	35
Other Students (Out-of-Province, RDH, Office)	80	53	84	108	89
Exhibitors	2,504	2,553	2,679	2,738	2,873
Other Registration Categories	298	250	201	1,125	241
Total Attendance	11,689	11,456	12,124	13,774	12,201
Total Booths	610	623	632	663	677
Total Exhibiting Companies	319	319	338	330	321



Important Dates, Deadlines and Early Bird Pricing

Applications for Exhibit Space and Applicable Deposit:

Deposit of \$1,000 CAD per 10' x 10' booth is required at time of booking. **Space will not be assigned until the deposit is received.**

Registration for 1st Round Booth Applications Opens for exhibitors with 50 or more ASM Exhibitor Loyalty Points. APPLICATION DEADLINE: September 19, 2018	September 12, 2018 12:00 noon (EST)	GES Advance Warehouse Begins: April 1, 2019
Registration for 2nd Round Booth Applications Opens for exhibitors with 25 to 49 Exhibitor Loyalty Points. APPLICATION DEADLINE: October 10, 2018	October 3, 2018 12:00 noon (EST)	Fire Safety Reply Email completed form and necessary floor plans to: Metro Toronto Convention Centre, Operations Department fsr@mtccc.com April 4, 2019
Registration for 3rd Round Booth Applications Opens for exhibitors with 10 to 24 ASM Exhibitor Loyalty Points. APPLICATION DEADLINE: October 31, 2018	October 24, 2018 12:00 noon (EST)	Certificates of Insurance Due Please submit to: info@exhibitorinsurance.com Online ordering: www.exhibitorinsurance.com April 11, 2019
Registration for 4th Round Booth Applications Opens for exhibitors with less than 10 ASM Exhibitor Loyalty Points. APPLICATION DEADLINE: November 21, 2018	November 14, 2018 12:00 noon (EST)	Exhibitor Appointed Contractor (EAC) Form Submit completed forms to: Email: yhafzopoulos@oda.ca Fax: 416-922-9571 April 11, 2019
Applications received after November 21, 2018 will be processed on a first come first served basis.		Lead Retrieval Services Early Bird Deadline Convention Data Services (CDS) April 15, 2019 Attendee Badge scanning
Preliminary Guide Advertising Space Closing November 5, 2018 Material Closing November 12, 2018		GES, Global Experience Specialists Early Bird Deadline April 15, 2019 carpet, furniture, plants, signage and other related design elements for your booth.
Hotel Reservations Room blocks for ASM19 will be open for Exhibitors in December. Notification will be emailed to all registered exhibitors prior to room blocks opening. December 4, 2018		Metro Toronto Convention Centre (MTCC) Early Bird Deadline April 23, 2019 Internet and Parking Passes Online Ordering: www.mtccc.com/order
FINAL BOOTH PAYMENTS DUE JANUARY 15, 2019		SHOWTECH Power & Lighting Early Bird Deadline April 23, 2019 Electrical and Sign Hanging Services
Cancellation of Booth Space Booth cancellations will be subject to a fee of \$1,000 per 10x10 booth prior to this date. Prior to February 15, 2019		Freeman Audio Visual Early Bird Deadline April 29, 2019 AV Requirements
No refunds will be given for booth cancellations after this date. All cancellations must be submitted to the ODA in writing after this date. After February 15, 2019		GES Advance Warehouse Deadline: April 29, 2019
Submissions Due for Complimentary Exhibitor Listing in the Final Program February 15, 2019		Direct Shipment to the MTCC May 7, 2019 Shipments will be refused prior to these dates/times. 12:00 noon – 9 pm May 8, 2019 8 am – 9 pm
Hanging Signs, Banners and Trusses February 15, 2019 Submission deadline for approval.		Exhibitor Badge Registration There is no deadline to register or make changes to your badges for exhibit booth staff. Register online any time before going to show site!
Booth Configuration Approvals February 15, 2019 Submission deadline for Island, Peninsula, and Full Aisle booth configurations and those booth configurations of 400 sq. ft. (four booths or more)		Exhibitor Move-In Times Tuesday, May 7 from 12:00 noon – 9:00 pm Wednesday, May 8 from 8:00 am – 9:00 pm
Advertising in the Final Program Space Closing March 11, 2019 Material Closing March 29, 2019		Please refer to the 'Move-In Schedule' for your designated move-in time.

EXHIBIT FLOOR IS OPEN

Thursday, May 9 from 9:00 am – 5:30 pm

Friday, May 10 from 9:00 am – 5:30 pm

There are no exhibits on Saturday, May 11

Booth Rental Information

The Ontario Dental Association (ODA) will not accept exhibits that do not comply with ODA By-laws, ODA Policy or where the exhibiting and/or display of such products or services would constitute the promotion of a product known to be hazardous to health.

The display of any product should not be construed as an endorsement of/or approval by the Ontario Dental Association. The exhibitor agrees not to imply in any way to a third party that acceptance as an exhibitor constitutes endorsement of a product or service by the Ontario Dental Association.

The Ontario Dental Association reserves the right to refuse to rent exhibit space at the Annual Spring Meeting as it shall, in its sole discretion, decide upon.

Health Canada Regulations – Class II, III and IV Medical Devices

In Canada, certain devices must have a **Medical Device License** before they are permitted to be sold. Prior to selling a device in Canada, manufacturers of Class II, III and IV devices must obtain a Medical Device License. Unlicensed Class II, III and IV medical devices are prohibited from being displayed and/or sold at the ASM.

New Exhibitors

To be considered as a new ASM Exhibitor, please visit asm.oda.ca and complete the '[New Exhibitor Application](#)' form. Please note that the approval process may take up to 2-3 weeks.

Cancellation Policy

- **Cancellation of booth space prior to February 15, 2019 will be subject to a charge of \$1,000 per 10'x10' booth space.**
- **No refunds will be given for cancellations received after February 15, 2019.**
- All cancellations must be in writing.
- In the event any irreconcilable dispute shall arise between any exhibitor/sponsor and the ODA, the ODA reserves the right to terminate the agreement between such party(ies) and itself and to make such financial refund(s), if any, in whole or in part to the exhibitor/sponsor as the ODA in its sole discretion deems appropriate; provided that the said decision of the ODA shall be final and binding on the parties herein.

Booth Assignment: ASM Loyalty Points System

In processing booth applications, the booths are allocated based upon the ODA's ASM Loyalty Points System. Every effort will be made to provide exhibitors with their requested spaces, or one(s) in a similar area or configuration. However, **we cannot guarantee that the location requested on the application will be the space assigned.**

This Loyalty System is comprised of historical information contained in the ODA's exhibit contract records dating back to 1927, and includes the following elements:

- The number of years a company has exhibited at ODA Annual Spring Meetings. (One Loyalty Point is allocated for each year a company exhibits.)
- The number of booths taken by that company during those years. (One Loyalty Point is allocated for each 10' x 10' booth a company takes during those years.)
- Loyalty Points accumulated through a company's involvement in the ASM Sponsorship Program.
- Ties between companies with identical scores will be broken using the date the application with the deposit is received.

Booth Rental Information

What's INCLUDED in the Booth Rental Fee

- 10' by 10' draped exhibit booth (3' side walls x 8' back walls)
- On-site storage of exhibitor's crates
- All material handling charges
- Janitorial services within the booth (Wednesday and Thursday nights)
- Janitorial services in the general exhibit area and aisles
- 24-hour security
- 5 exhibit badges per 10' x 10' booth

(Additional badges may be ordered for a fee of \$30 per badge).

PLUS...

- Use of the **Exhibitors' Lounge** on-site at the ASM, where complimentary refreshments are available on Thursday and Friday during show hours. ODA Exhibit badges must be worn to gain entry to the Exhibitors' Lounge.
- **Cocktail Receptions** on the exhibit floor, Thursday and Friday from 4:30 pm – 5:30 pm. Each exhibitor will receive a ticket for a complimentary drink.
- **Complimentary listings** in Final Program, ODA Website, Mobile App, and On-site Exhibitor Directory.

What's NOT INCLUDED in the Booth Rental Fee

- Electrical is NOT included in the rental fee. Electrical requirements may be ordered directly through SHOWTECH Power and Lighting.
- Carpeting
- Furnishings
- Sign and banner hanging
- Internet access
- Transportation
- Advance warehousing
- Telecommunications

PLEASE NOTE: Booth carpeting/flooring is a mandatory requirement.

Booth Fees

See floorplan pages 14-15 for location details

NOTE: Fees are in CDN\$ and do not include 13% HST

Booths in Area A

- Regular booths \$2,995
- Corner booths \$3,195

Booths in Area B

- Regular booths \$2,725
- Corner booths \$2,925

Booths in Area C

- Regular booths \$2,525
- Corner booths \$2,725

Meeting Room 10' x 10' \$2,500

Meeting Room 20' x 20' \$4,500

Exhibitor Warnings

Exhibitor Listings

The ODA only collects exhibitor information for the ASM through your Expocad Exhibitor Account.

Please be aware of companies requesting your information for a "Free Exhibitor's Directory Listing". If you sign an insertion order from one of the companies listed below, you may be entering into a three-year advertising contract.

Do Not Respond to Requests From the Following Companies/Publications:

- FairGuide – Construct Data (Slovakia)
- Expo-Guide – (Mexico)
- International Fairs Directory
- EventFair – The Exhibitors Index for Fairs and Exhibitions
- World Business Guide – International Directories Group

For more information, please visit:

http://www.iaee.com/resources/warnings_to_exhibitors/

Official ASM Hotel Room Blocks

The ODA does not have a housing bureau or travel agent authorized to make hotel reservations related to the Annual Spring Meeting. Please make your reservations directly with the hotel.

Attendee Lists

The ODA is compliant with the Privacy Laws and the Anti-Spam Legislation. We do not sell our attendee list therefore if you receive an email claiming the sale of this information, please do not respond and delete it immediately.

Dental Tribune

The ODA does not have a partnership with the Dental Tribune and we do not promote the sale of advertising space in this publication. We are aware that this publication is distributed onsite at many other dental meetings but it is NOT DISTRUBUTED ONSITE AT THE ASM.

Move-In/Move-Out

Exhibitor Move-In

The trade show will be located in Exhibit Halls D and E in the South Building of the Metro Toronto Convention Centre, which is located at 222 Bremner Blvd., one block north of Lakeshore Blvd., West at York Street.

- As per the Ministry of Labour, children under 16 years of age are NOT permitted on the show floor during move-in or move-out.
- No material may be taken through the main entrance unless it can be carried by hand.
- Dollies are not allowed on carpeted areas.
- No equipment may be transported on the escalators or public passenger elevators.
- Exhibitors must provide their own labour for spotting, erecting and dismantling of their exhibits. Skids must be used for all heavy pieces of equipment.
- Double-sided Scapa tape, low tack cloth gaffer tape or TransRite are the only tapes permitted for use in the exhibit hall. All tape must be removed prior to vacating the space or charges will apply.

All unloading, loading and removal of equipment and materials to the booth and to and from on-site storage is included in your exhibit booth rental fee.

Exhibit Floor Dates and Times

Exhibitor Move-in	Tuesday May 7, 2019 12:00 noon – 9:00 pm	Wednesday May 8, 2019 8:00 am – 9:00 pm	
Exhibitor Registration/Badge Pick-up	Wednesday May 8, 2019 10:00 am – 7:00 pm	Thursday May 9, 2019 7:00 am – 5:30 pm	Friday May 10, 2019 7:00 am – 5:30 pm
Exhibit Floor Open	Thursday May 9, 2019 9:00 am – 5:30 pm	Friday May 10, 2019 9:00 am – 5:30 pm	
Exhibit Floor Cocktail Reception	Thursday May 9, 2019 4:30 pm – 5:30 pm	Friday May 10, 2019 4:30 pm – 5:30 pm	
Exhibitor Move-out	Friday May 10, 2019 5:30 pm – 10:00 pm	Saturday May 11, 2019 8:00 am – 12:00 noon	

Metro Toronto Convention Centre – Protective Footwear Policy



On May 28, 1998 the Ministry of Labour conducted a site tour of the MTCC facilities and determined that the exhibit levels during a move-in and move-out are considered construction sites, therefore, all workers must wear protective footwear as stipulated in the Occupational Health & Safety Act. The Occupational Health & Safety Act states “A worker exposed to the hazard of a foot injury shall wear foot protection appropriate in the circumstances” (R.R.O. 1990 reg 851-S82).

All exhibitors, display and show managers and exhibit/display company employees who work on the exhibit levels during a move-in and move-out must wear protective footwear. Anyone found not wearing approved safety shoes will be immediately asked to leave the exhibit hall.

Safety in the workplace is an important issue for all of us and the ODA and the MTCC appreciates your full co-operation and support with this important issue.

PLEASE NOTE: Exhibitors without protective footwear will not be permitted to gain entry into the exhibit hall during the move-in.

Move-In/Move-Out

Exhibitor Move-Out

- **Removal of exhibits may commence no sooner than 5:30 pm, Friday, May 11, 2019** until 10:00 pm and from 8:00 am to 12:00 noon on Saturday, May 11, 2019.
- As per the Ministry of Labour, children under 16 years of age are NOT permitted on the show floor during tear down or move out. **Please also note, that as per the Ministry of Labour, Proper Protective Equipment is required to be worn while all tear down and move out activity is taking place.**

Empty Removal Instructions

- All Exhibitors must have all crates tagged for empty storage by 2 hours prior to end of exhibitor move-in. GES Material Handling Team need to remove all empty crates in order to be ready for aisle carpet install by 11pm on Wednesday, May 8th.
- At show closing, GES will remove aisle carpet which will take approximately 1 hour. Once aisle carpet is removed, GES will deliver empty storage crates to your booth – storage return will take up to 4 to 5 hours. Please keep aisles free of booth materials until aisle carpets are removed. We ask for your co-operation and patience.
- All electrical power will be turned off 1/2 hour after show closes unless prior arrangements have been made with SHOWTECH Power & Lighting.
- You may obtain a flat-bed dollie from GES Material Handling Desk. Dollies will be released after the aisle carpet is removed.

Outbound Freight

The South Loading Docks will be used for move-out. To ensure a smooth and secure move-out of your freight, visit the GES Exhibitor Service Desk to pick-up an **Outbound Bill of Lading (BOL)** form. Outbound BOL's **MUST** be completed for your materials to be loaded onto your carrier or your freight will not be released from the show floor. Once your materials are packed and ready to go, return the completed BOL to the GES Material Handling Desk located on the south loading docks.

PLEASE DO NOT LEAVE THE COMPLETED BILL OF LADING IN YOUR BOOTH.

- When your material is ready, you will be given a pass by MTCC Dock Staff to either bring your parked vehicle into the Dock or your vehicle will be called from the Marshalling Yard at that time. **PLEASE NOTE THAT YOU WILL NOT BE ABLE TO MOVE YOUR VEHICLE INTO THE DOCK AREA WITHOUT A PASS.**

NEW! Hand Carry Items

There are 2 new service freight elevators located and accessible for any hand carry out items from within the South Building Parking Garage. When your booth is packed and ready to go, you can hand carry your items to your vehicle using the NEW Service Elevators located at the north end of Hall E. These elevators can accommodate a flat bed dollie. The elevator will stop directly into the South Parking Garage. If you require the use of a dollie, you will be asked to leave your ID and once the dollie is returned your ID will be returned.

- No material may be taken through the Main Entrance on Bremner Blvd. unless it can be carried by hand. Dollies are not allowed on carpeted areas. No equipment may be transported on the escalators or public passenger elevators. All 4 wheel dollies, pallet jacks or oversize loads are prohibited from leaving all Exhibit Halls into the pre-function areas. If you require a dollie or pallet jack to move your items to your vehicle, you must use the designated loading area.
- In order to minimize the risk of theft during move-out, it is recommended that all small articles of value be removed at the close of the show and that the exhibitor guards the remaining material.
- **All exhibits must be removed from the show floor by 12:00 noon on Saturday, May 11, 2019. Please ensure that you have made arrangements with your shipper to remove your goods from the floor at this time. The official carrier will remove all materials left on the floor past 12:00 noon at the owner's expense.**
- If you need help with moving your freight, please speak with a GES representative on the show floor.
- **Any Exhibitor found to be in violation of dismantling their booth prior to 5:30 pm on Friday, May 10, 2019 will be subject to penalties as outlined in the Ontario Dental Association's "Compliance With Terms of Exhibit Space Rental"**

SMALL VEHICLES (i.e. SUV, Van, Pick-up Truck or Personal Car) NO Loading Assistance Required

When your booth is packed and ready to go, please obtain a **LOADING AREA Pass**, which allows your small vehicle access to the South Dock loading area. Passes are available from the MTCC Dock Staff (in red coats) at the dock area during move-out.

The driver of your vehicle must have the loading pass to enter the dock area and you must load your own vehicle. Vehicles are prohibited from parking on surrounding streets and are subject to tagging and towing from the City of Toronto.

LARGE VEHICLES (i.e. Cube Van, 16ft Rental Truck or larger; Freight Transporter, etc.)

*****MUST go to the Marshalling Yard and Requires a Bill of Lading******

When your material is ready you will be given a pass my MTCC Dock Staff to either bring your parked vehicle into the Dock or your vehicle will be called from the Marshalling Yard as space becomes available in the dock area. **PLEASE NOTE** that you will not be able to move your vehicle into the Dock Area without a pass.

Move-In/Move-Out



Metro Toronto Convention Centre South Building, Loading Docks and Marshalling Yard

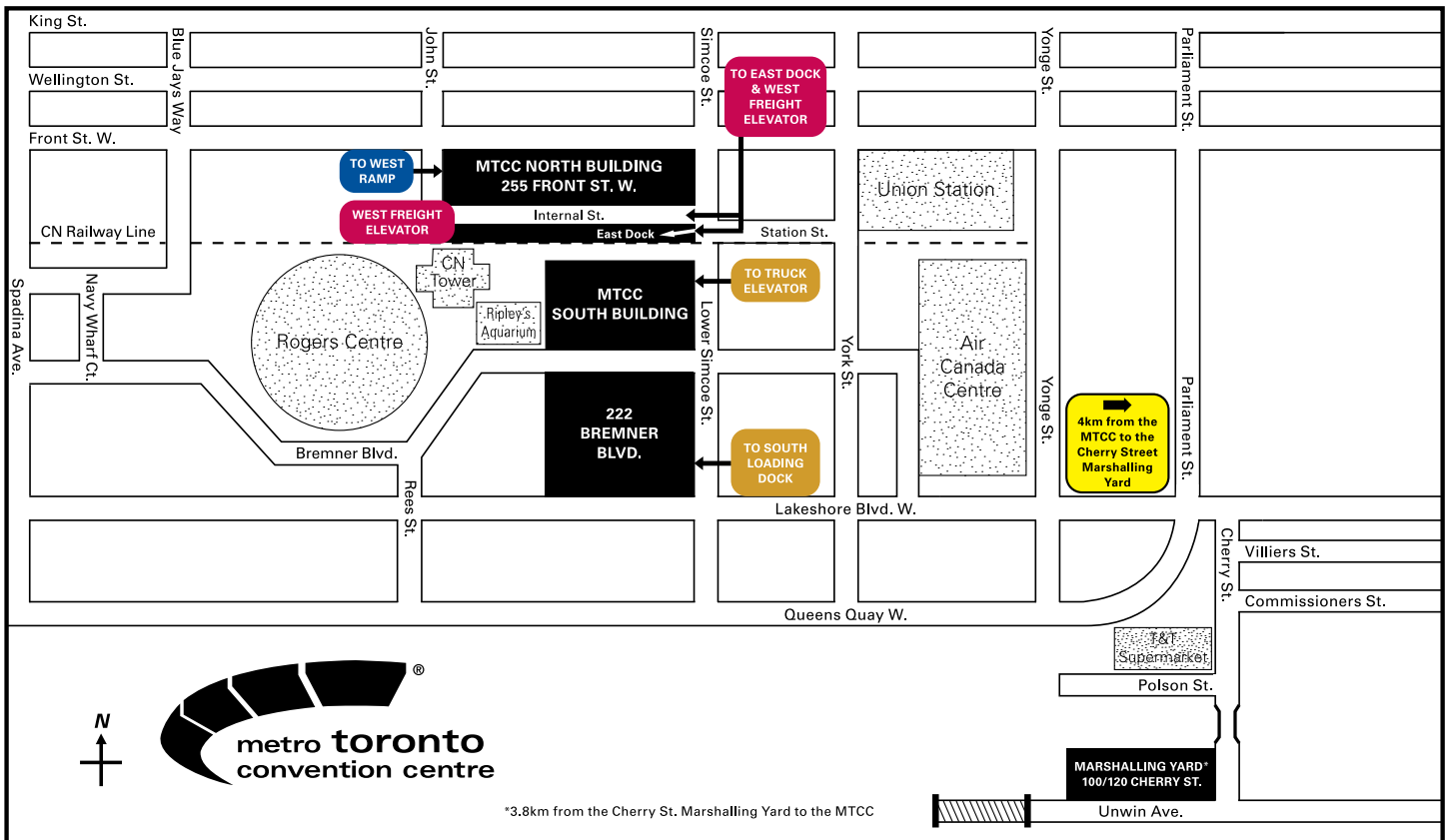

Map is not to scale

LOADING DOCK ACCESS

The South Building Loading Docks will be open for replenishment purposes on Friday May 10, 2019 from 7:30 am to 11:30 am

MOVE-IN TIMES

Tuesday, May 7 from 12:00 noon – 9:00 pm
 Wednesday, May 8 from 10:00 am – 7:00 pm

ALL EXHIBITS MUST BE IN PLACE BY 9:00 pm, Wednesday, May 8, 2019, and ready for the 9:00 am opening of the ASM on Thursday, May 9, 2019
 Please refer to the Move-In Schedule for your specific move-in time.

Move-In/Move-Out

Vehicle Marshalling

A marshalling yard has been established at 100/120 Cherry Street in order to facilitate move-in and move-out of events at the Metro Toronto Convention Centre.

Move-in/out information/bulletins will be provided by Show Management. Any variations to the procedures listed below will be indicated as such on the move-in/out information/bulletins.

PROCEDURES

1. **SMALL VEHICLES (i.e. SUV, Van, Pick-up Truck or Personal Car) NO Loading Assistance Required**

When your booth is packed and ready to go, please obtain a **LOADING AREA Pass**, which allows your small vehicle access to the South Dock loading area. Passes are available from the MTCC Dock Staff (in red coats) at the dock area during move-out.

The driver of your vehicle must have the loading pass to enter the dock area and you must load your own vehicle. Vehicles are prohibited from parking on surrounding streets and are subject to tagging and towing from the City of Toronto.

2. All vehicles will report first to the vehicle marshalling area. This lot is 3.8 km from the Convention Centre. The marshalling yard is open 1 hour prior to scheduled move-in/move-out times.
3. An attendant will be posted at the marshalling area. The attendant will assign the delivery order of the vehicles and give a numbered ticket to the driver based on a prearranged priority listing produced by show management. The cost of the attendant will be at the expense of the Convention Centre when required during operational hours of 0700–2359. Charges will be applied between 0001–0700.
4. A call will be made to the attendant to dispatch vehicles. As space becomes available, the drivers will be directed to the South Building (Lower Simcoe Street).
5. Upon arrival at either entrance, the driver will turn in their assigned tickets.
6. Vehicles entering the loading dock areas will be met by the Convention Centre dock staff who will control the flow of vehicle traffic.
7. Vehicles going to the South Building Exhibit Floor will be met by dock staff positioned at Lower Simcoe Street and on the ramp to control the pedestrian traffic on the ramp.
8. During the winter season, the Convention Centre will bear the cost of the labour and equipment to keep the ramp open to traffic, to clean off vehicles before going onto the floor and to keep the floor clean. The Centre will also be responsible for snow removal in the marshalling area.
9. The control of the vehicles once onto the Exhibit Floor will be the responsibility of Show Floor Management in conjunction with the Convention Centre dock staff.
10. Freight elevators, when in use, will be manned and controlled by operators supplied by the Convention Centre.
11. Vehicle storage is available during events at \$32.00 plus 13% HST per day. Arrangements must be made in advance through the Dock Office at (416) 585-8345

NOTE

Vehicles will be held in the marshalling yard before and after Rogers Centre events where pedestrian and vehicular traffic block access to the ramp. Times for these periods will be scheduled on an individual basis as schedules warrant. Vehicle marshalling inquiries – Tel: (416) 585-8345.

Exhibitor Registration Information

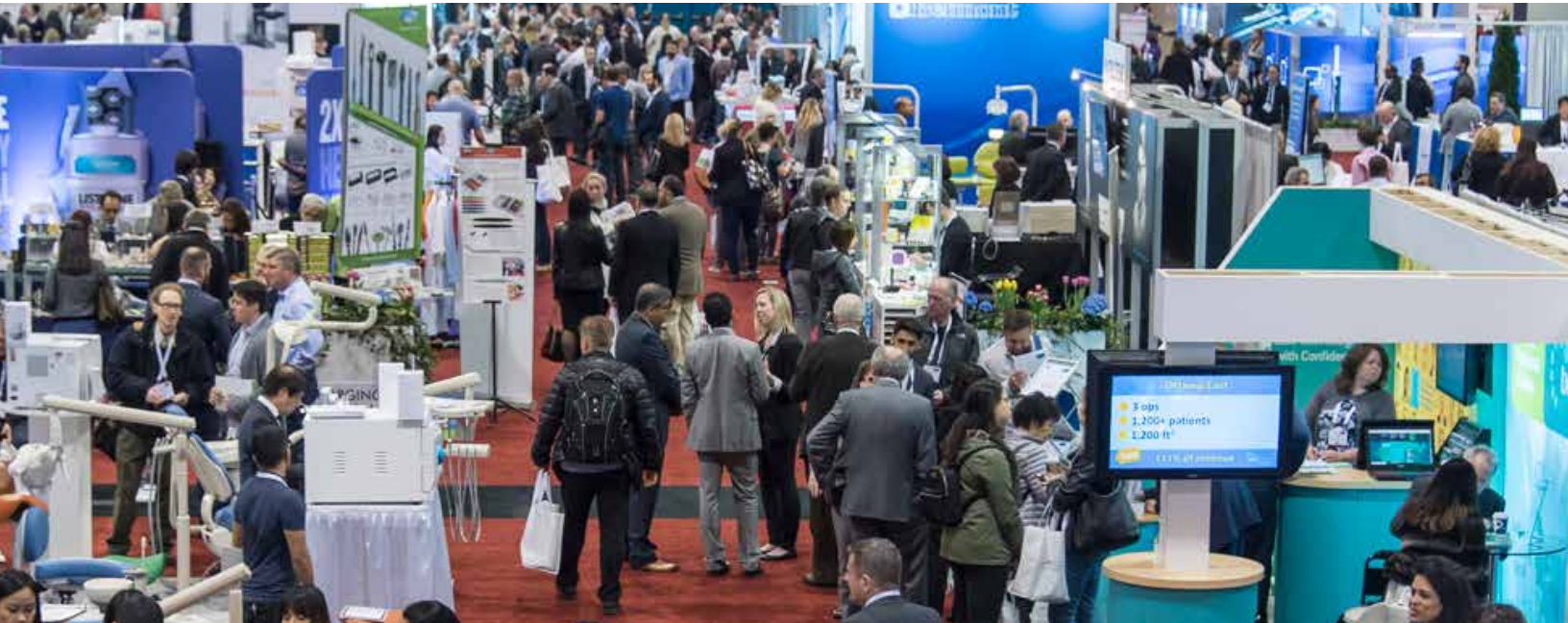

Exhibitor Badge Registration

The ASM19 Exhibitor Registration website will be open for exhibitors to register booth personnel in January 2019. Email notifications will be sent to all registered exhibitors with the website link and log-in information.

PLEASE NOTE: On-site exhibitor registrations will require photo ID and proof of employment with the exhibiting company. Accepted proof may include a business card or a letter from the exhibiting company to verify the individual as booth staff for the ASM.

For security and safety reasons, **EXHIBITOR BADGES MUST BE WORN AND VISIBLE AT ALL TIMES** during the ASM show hours. On-site security will be checking badges during the show. Individuals without red badges will be asked to leave the show floor.

Badges may be picked up from the Exhibitor Registration Desk on Level 600 during the following hours:

Wednesday, May 8	10:00 am – 7:00 pm
Thursday, May 9	7:00 am – 5:30 pm
Friday, May 10	7:00 am – 5:30 pm

Media Relations

Any and all media-related activities for exhibits must be channeled through Maggie Blood, mblood@oda.ca.

ASM19 Badge Colours

- Red** – Exhibitor
- Blue** – All Dentists
- Orange** – Dental Student
- Green** – Dental Hygienist, Dental Hygienist Student
- Purple** – Dental Assistant, Office Manager, Receptionist, Dental Assistant Student
- Brown** – Dental Technologist
- Black** – Press, Visitor
- Clear** – ODA Staff/Support Staff

Hotel Reservations

The ODA does not have a housing bureau or travel agent authorized to make hotel reservations related to the Annual Spring Meeting. Exhibitors are responsible for making their own hotel room reservations. Please make your ASM reservations directly with one of the designated hotels. Room blocks will be open to exhibitors on December 4, 2018. Please visit our website at asm.oda.ca to reserve your accommodations online.

Conference Session Breaks

- 9:00 am – 10:00 am** Following the Opening Keynote Session on Thursday and Friday
- 12:00 am – 2:30 pm** Lunch break on Thursday and Friday
- 4:30 pm – 5:30 pm** End of sessions on Thursday and Friday

Hotel Accommodation

Official 2019 ODA ASM Hotels

Room blocks will open up on December 4, 2018. Book early to ensure your choice of hotel. Rooms are available on a first-come, first-served basis.

The hotels featured in the *Exhibitor Prospectus* are holding room blocks at preferential group rates for the ODA 2019 Annual Spring Meeting Conference and Trade Show. Rooms should be reserved directly with your preferred hotel. Please let hotel reservations staff know that you are attending the ODA Annual Spring Meeting in order to qualify for these rates.

The ODA does not have a convention bureau or travel agent authorized to make hotel reservations related to the Annual Spring Meeting.



1 Hotel Le Germain Maple Leaf Square

75 Bremner Boulevard
 Toronto, ON M5J 0A1
 Tel: 416-649-7575
 Toll Free: 1-800-916-4339

Single Room: \$299
 \$30/night extra for double occupancy



2 InterContinental Toronto Centre

225 Front Street West
 Toronto, ON M5V 2X3
 Tel: 416-597-1400
 Toll Free: 1-800-235-4670

Single/Double Room: \$259



3 Hyatt Regency Toronto on King

370 King Street West
 Toronto, ON M5V 1J9
 Tel: 416-343-1234
 Toll Free: 1-800-233-1234

Single/Double Room: \$225



4 Delta Toronto

75 Lower Simcoe Street
 Toronto, ON M5J 3A6
 Tel: 416-849-1200
 Toll Free: 1-888-890-3222

Single/Double Room: \$275



5 The Fairmont Royal York Hotel

100 Front Street West
 Toronto, ON M5J 1E3
 Tel: 416-368-2511
 Toll Free: 1-800-441-1414

Fairmont Room: \$244



● TTC Subway Station ■ Hotel



6 Toronto Marriott City Centre Hotel

1 Blue Jays Way
 Toronto, ON M5V 1J4
 Tel: 416-341-7100
 Toll Free: 1-800-237-1512

Single/Double Room: \$228



7 Radisson Admiral on Queen's Quay

249 Queen's Quay West
 Toronto, Ontario M5J 2N5
 Phone: 416-403-3333
 Toll Free: 855-516-1090

Single/Double Room: \$211



8 Westin Harbour Castle Hotel

1 Harbour Square
 Toronto, ON M5J 1A6
 Tel: 416-869-1600
 Phone: 416-869-1600

Single/Double Room: \$265

For hotel links, please visit asm.oda.ca

Official Show Services Suppliers

TRUCKING/FREIGHT SERVICES

GES CANADA Logistics

Mario Mendes, Logistics Coordinator
5675 McLaughlin Road, Mississauga, ON L5R 3K5
Tel: 905-283-0553 • Fax: 905-283-0501
Email: mmendes@ges.com

CUSTOMS BROKERAGE SERVICES

GES CANADA Customs Services

Maria Brava
5675 McLaughlin Road, Mississauga, ON L5R 3K5
Tel: 416-585-8227 Fax: 905-283-0501
Email: mbrava@ges.com

MATERIAL HANDLING SERVICES

GES CANADA

Toronto Exhibitor Services
5675 McLaughlin Road, Mississauga, ON L5R 3K5
Tel: 905-283-0500 • Fax: 905-283-0501
Email: torontoexhibitorservices@ges.com

SHOW SERVICE REQUIREMENTS

- BOOTH CARPETING, FURNISHINGS, PLANTS, SIGNS, ETC.

GES CANADA

Toronto, Exhibitor Services
5675 McLaughlin Road, Mississauga, ON L5R 3K5
Tel: 905-283-0500 • Fax: 905-283-0501
Email: torontoexhibitorservices@ges.com

LIGHTING AND ELECTRICAL REQUIREMENTS

- FOR AIR, GAS AND PLUMBING SERVICES

SHOWTECH Power and Lighting

Tracy Landry
Metro Toronto Convention Centre
255 Front Street West, Toronto, ON M5V 2W6
Tel: 416-585-8109 • Fax: 416-585-8255
Email: tlandry@showtech.ca

EXHIBITOR INSURANCE

Exhibitorinsurance.com

2780 Highway #7, Unit 103, Concord, ON L4K 3R9
Tel: 905-695-2971 x103 • Fax: 905-760-2260
Email: info@exhibitorinsurance.com

AUDIO-VISUAL SERVICES

Freeman Audio Visual Canada

David Bartelli
Account Executive, Metro Toronto Convention Centre
2365 Matheson Blvd. East, Mississauga, ON L4W 5C2
Tel: 905-366-9200
Email: david.bartelli@freemanco.com

INTERNET AND TELECOMMUNICATIONS INSTALLATION

Metro Toronto Convention Centre

Iain Holland
255 Front Street West, Toronto, ON M5V 2W6
Tel: 416-585-3596 • Fax: 416-585-8224
Email: iholland@mtccc.com

LEAD RETRIEVAL SERVICES (Attendee Badge Scanning)

Convention Data Services

Steve Barove
Sr. Exhibitor Services Account Manager
Direct: 508-743-0112
Email: sbarove@cdsreg.com

EXHIBITOR BADGE REGISTRATION

Convention Data Services

Tel: 877-779-3127
Email: ASM@xpressreg.net

Exhibitor Service Centre

To access the Exhibitor Service Centre, visit the ASM website, asm.oda.ca and click on “Exhibitors” in the top menu. Here, you will have access to all of the important information, forms and website links you will require for exhibiting at the ASM19, including:

Show Information:

- Important Dates and Deadlines
- Submit Complimentary Exhibitor Listing
- Move-in Information
- Exhibitor Badge Registration
- Hotel Information
- Interactive Floor Plan
- Preliminary Guide / Final Program
- Official Service Providers

Show Forms:

- Exhibitor Insurance
- GES Booth Furnishings

- MTCC Forms (Parking Pass, Internet, etc.)
- Freeman Audio Visual
- SHOWTECH Power and Lighting
- CDS Lead Retrieval

Shipping, Drayage and Material Handling:

- Advance Warehousing
- Shipping and Material Handling
- Customs – Canada Border Services
- Exhibitor Move-In, Move-Out Information

Marketing Tools:

- Social Media (Facebook, Twitter)
- Banner Graphics
- Mobile App

Shipping Information

Direct Shipments to Show Site

Shipment of materials should be timed to arrive at the Metro Toronto Convention Centre no earlier than **Tuesday, May 7, 2019** or they will be turned away as the Ontario Dental Association does not have access to the loading docks until that date.

Please label your shipment as follows:

c/o GES, ODA Annual Spring Meeting 2019
 Exhibiting Company Name, Booth # _____
 Metro Toronto Convention Centre – South Building
 222 Bremner Boulevard, Toronto, Ontario M5V 3L9

Shipping labels can be printed from the Exhibitor Service Centre website!

Shipping Instructions for United States and International Exhibitors

- US and International Exhibitors should either contact Maria Brava of GES CANADA Customs Services (see Official Show Services Suppliers list, page 12), or your own customs broker at least **one month** before the Annual Spring Meeting to discuss Canadian importing procedures for your show freight.
- There are a variety of transportation options available to you and GES CANADA as the official transportation company would be happy to provide you with a quote. For Exhibitors who choose to transport their materials in their own private vehicle, it is necessary that you contact GES Customs four weeks in advance so that the proper documentation can be prepared for the border crossing.
- Shipments should be timed to arrive one week before the meeting date.
- Delivery will be made by the carrier to the loading docks during the designated move-in time. GES CANADA will move your shipment from the receiving doors to your designated booth space.
- There is no duty or tax on exhibits being shipped temporarily into Canada for exhibition purposes, provided they do not remain in Canada at the end of the event however, all International and USA shipments will be subject to Customs clearance and associated fees. For US and International Exhibitors at Canadian meetings, duty and taxes must be paid on advertising literature and giveaway samples. Please note that all printed matter from the United States must be marked "Printed in the USA".
- All fees associated with Transportation and Customs must be pre-paid.
- Shipments must be returned to the US and/or Internationally with the same number of packages originally shipped into Canada. Should any material be sold and remain in Canada, applicable duties and taxes will be due.

Shipments to Advanced Warehouse

Start Date: April 1, 2019 **Deadline Date:** April 29, 2019

Warehouse receiving hours: Monday – Friday, 9:00 am to 4:00 pm, Closed Holidays

Please Note: Advance warehouse services do not include material handling services and charges.

Shipments arriving before April 1, 2019 will incur a storage fee, and shipments arriving after April 29, 2019 will incur a Late to Warehouse Fee.

IMPORTANT! ADVANCE WAREHOUSE SERVICES INCLUDES DELIVERY TO SHOW SITE ONLY. YOUR CARRIER MUST PICK UP YOUR MATERIALS DIRECTLY FROM SHOW SITE AT CONCLUSION.

Please label your shipment as follows:

ODA Annual Spring Meeting 2019
 Exhibiting Company Name/Booth # _____
 c/o GES CANADA, 6130 Netherhart Road
 Mississauga, Ontario L5T 1B7

**If you have any shipping inquiries, please contact
 Mario Mendes at GES CANADA at 905-283-0553 or Email: mmendes@ges.com**



- AREA A
- AREA B
- AREA C

Rules and Regulations

Compliance with Terms of Exhibit Space Rental

The Ontario Dental Association reserves the right to take such action and to make such changes as are considered necessary to the efficient and proper conduct of the exhibition and/or to protect the rights of the Ontario Dental Association.

Non-compliance with booth conditions and exhibitor rules and regulations as determined by the Ontario Dental Association can result in the removal of the offending exhibitor, the closing of his/her exhibit, and/or the refusal to allow the exhibitor to participate in future Ontario Dental Association events, without indemnity, and the Ontario Dental Association is released from any and all claims for damage which might result in consequence thereof.

Infractions identified at the meeting will be dealt with after the event and a penalty established, if deemed necessary, at the discretion of the Education Advisory Committee.

Penalties for Violations

Exhibitors who violate regulations will be subject to the following penalties as deemed appropriate by the Education Advisory Committee.

FIRST OCCURRENCE – loss of the current year's Loyalty Points accumulation

SECOND OCCURRENCE – loss of half of the exhibiting company's accrued point accumulation

THIRD OCCURRENCE – loss of all of the exhibiting company's accrued Loyalty Points accumulation

FOURTH OCCURRENCE AND/OR EXTREME VIOLATIONS – loss of privileges to exhibit at future Ontario Dental Association events

The Ontario Dental Association reserves the right to move directly to "fourth occurrence/extreme violations" level penalties for those violations which it deems as extreme (for example, but not limited to: theft, violence, sabotage of other exhibitors or the Ontario Dental Association, major disruption of the event, criminal activity).

Booth Restrictions

- a. Unlicensed Class II, III and IV medical devices are prohibited from being displayed and/or sold at the ASM.**
- b.** Flooring/carpeting used within the confines of a booth space should cover the entire area and not reveal concrete between the booth and the aisle carpet.
- c.** No flashing lights may be used on booths.
- d.** No advertising image may be projected to a surface outside the confines of an exhibitor's booth.
- e.** Robots, or other remote control devices must stay within the exhibitor's space.
- f.** Mascots must remain within the confines of an exhibitor's booth and must not roam the aisles.
- g.** The Ontario Dental Association does not assume responsibility for any charges for special or extra carpentry work, shelving, decorations, furniture, etc. for individual booths or exhibits.
- h.** No signs or other articles are to be fastened to walls or fixtures or electrical equipment. Use of thumb tacks, screws, bolts or any tool or material which will mark the floor or wall is prohibited.
- i.** Use of masking, clear packaging and plastic-based tape are prohibited. To secure booth flooring to exhibit floor, only cloth-based tapes such as Polyken are acceptable. Labour/repair charges will apply to remove prohibited tapes from the Convention Centre property.
- j.** The rear or back of a booth, if visible above the pipe and draping, must be covered or finished in such a manner as not to distract from those booths behind it.
- k.** No exhibitor shall, without the written permission of the Education Advisory Committee, assign, sublet, or apportion the whole or any part of the space allotted nor exhibit therein any goods other than those manufactured or handled by the exhibitor in the regular course of his/her business or to take orders in the exhibitor's space for any such other goods.
- l.** Exhibitors must stay within the confines of their booth and not utilize the aisles for exhibit purposes or for solicitation of business.
- m.** If an exhibitor has booths on both sides of an aisle — no signs or structures above the aisle are permitted and the aisle may not be carpeted with the exhibitor's booth carpet.
- n.** Agents, solicitors and representatives of firms selling commercial products in connection with the Annual Spring Meeting will not be permitted to use sample rooms or space elsewhere in the Metro Toronto Convention Centre or the InterContinental Toronto Centre Hotel for display of their products. Advertising, solicitation and distribution of literature for commercial products is not permitted except in the exhibit halls and must be approved by the Education Advisory Committee.
- o.** The Ontario Dental Association reserves the right to prohibit the installation or enforce the removal of any exhibit which, in the opinion of the Ontario Dental Association or its designates, may be detrimental to the Annual Spring Meeting or to the interests of the Ontario Dental Association, or to cancel an exhibitor's contract at any time during the Annual Spring Meeting if any article exhibited hereunder is misrepresented.
- p.** The Ontario Dental Association reserves the right to restrict exhibits, which because of noise or any other reason become objectionable.
- q.** Any social event sponsored by an exhibiting company cannot take place within a 1km radius of the Metro Toronto Convention Centre during ASM exhibit hours.

Rules and Regulations

Health Canada Regulations

In Canada, certain devices must have a Medical Device License before they are permitted to be sold. Prior to selling a device in Canada, manufacturers of Class II, III and IV devices must obtain a Medical Device License. Unlicensed Class II, III and IV medical devices are prohibited from being displayed and/or sold at the ASM.

Payment of Booth Space

The rental amount is payment in consideration for the use by the Exhibitor of the area designated on the floor plan (the "Space") during the Annual Spring Meeting. The rental amount is stated according to rates quoted in the Exhibitor's Prospectus – Booth Rental Information (page 6). All payments for booth space must be received by the Association no later than January 15, 2019. For booth applications submitted after January 15, 2019, payment in full is due at the time of booking. The Ontario Dental reserves the right to re-allocate the 'Space' if payment is not received by the due date.

Cancellation Policy

All cancellations must be submitted to the Ontario Dental Association in writing. Cancellations of booth space prior to February 15, 2019 will be subject to a charge of \$1,000 per 10' x 10' booth space. No refunds will be given for cancellations received after February 15, 2019. In the event any irreconcilable dispute shall arise between any exhibitor or sponsor and the Ontario Dental Association, the Ontario Dental Association reserves the right to cancel the agreement between such parties and itself and to make such financial refunds, if any, in whole or in part, to the exhibitor/sponsor as the Ontario Dental Association in its sole discretion deems appropriate.

Booth Staffing

The exhibitor must keep their exhibit open and properly staffed during the specified exhibit hours, and shall not close or remove the exhibit until the conclusion of the entire exhibition, unless otherwise directed by the Education Advisory Committee.

Code of Conduct

The Ontario Dental Association is committed to maintaining an environment that encourages respect for the dignity of each individual. Discrimination, violence and/or harassment in any form, whether verbal, physical or environmental, which is directed toward a person's sex, race, age, marital status, disability, religion, national origin, sexual orientation, same-sex partnership status, or any other classification protected by law, is prohibited. The Ontario Dental Association considers violation of this policy a serious offence that will lead to penalties, which may include loss of privileges to exhibit at future Ontario Dental Association events.

Exhibit Badges

- Exhibit badges will be allocated on the basis of 5 badges per 10' by 10' booth, unless otherwise covered by the provisions of a sponsorship agreement with the Annual Spring Meeting. Additional badges, if required, may be purchased at \$30.00 each.
- Exhibit badges are to be worn by the person named on the badge only, and are not to be transferred to anyone else.
- Exhibit badges must be worn to gain entry to the Exhibitors' Lounge on-site at the ASM.

For security and safety reasons, **EXHIBITOR BADGES MUST BE WORN AND VISIBLE AT ALL TIMES** during the ASM show hours. On-site security will be checking badges during the show. Individuals without badges may be asked to leave the show floor.

Direct/Cash Sales/Handover of Goods

While orders for goods and services may be taken and payment made by cheque or credit card, no sales involving payment by cash may take place in the exhibit halls during the Annual Spring Meeting. There is to be no direct selling by exhibitors — goods may not be handed over during the Annual Spring Meeting, they must be delivered to the purchaser after the Annual Spring Meeting.

Distribution of Materials, Samples, and/or Food

- Distribution of sample products for consumption must receive approval from the Metro Toronto Convention Centre. Forms for such approval are available from the Ontario Dental Association.
- Only bona fide exhibitors may distribute advertising materials at the Annual Spring Meeting, and this distribution of materials may only take place within the confines of their booth, and not in any public areas such as the aisles, escalators, registration area or Food Court. Any materials that are left in public areas will be confiscated by security.
- All food and beverage (alcoholic or non-alcoholic) items served in exhibit booths must be co-ordinated/purchased from the Metro Toronto Convention Centre's Catering Department.



Rules and Regulations

Insurance

Exhibitors are responsible for their own booth insurance; this is mandatory.

The Ontario Dental Association is not responsible and/or liable in any way for any claim by a third party made on them for their fault or deemed negligence. The Ontario Dental Association will not be liable for any damage or theft of inventory.

Each vendor is required to have proof of a Certificate of Insurance that includes the following:

- Commercial General Liability Insurance with a minimum of \$2,000,000 in coverage
- Products and Completed Operations, Tenants Legal Liability and cross liability should be included in the General Liability
- Please ensure that the Ontario Dental Association is listed as an 'additional insured' with respect to this event.

Proof of exhibitor insurance is required prior to the move-in date.

Please send Certificates directly to:

www.exhibitorinsurance.com.

2780 Hwy 7, Unit 103, Concord, ON L4K 3R9

Fax: 905-760-2260 | Email: info@exhibitorinsurance.com

Exhibitor Liability

The Exhibitor agrees to assume and shall be expressly liable for any and all liability for the negligence or willful acts of omission by itself, its agents, servants and employees, including, without limitation, liability arising from any damage to floors (including carpeting), walls, columns, or to standard exhibit equipment at the Metro Toronto Convention Centre or to other exhibitors' property located thereat. The Exhibitor agrees that it will indemnify and hold harmless the Association from and against any and all losses, claims, suits, damages and liabilities of any kind caused by or arising from personal injury or property damage sustained by any person arising out of the transfer, installation, maintenance, removal or operation of the Exhibitor's exhibit or arising out of any breach or non-performance by the Exhibitor of any of the terms and conditions set forth in the Contract.

Security, Responsibility for Loss or Damage

Neither the Ontario Dental Association nor the Metro Toronto Convention Centre is responsible for loss or damage which might ensue from any cause in connection with transfer, installation, maintenance or removal of exhibits. Neither the Ontario Dental Association nor the Metro Toronto Convention Centre will be responsible in any way for goods while on exhibit or in storage. Security guards will be on duty, but neither the Ontario Dental Association nor the Metro Toronto Convention Centre will assume responsibility for loss or damage caused to exhibitors by theft or otherwise. It is suggested that exhibitors

accompany their merchandise and/or goods to their booth if at all possible. The Ontario Dental Association has been advised that the greatest risk of theft occurs during set-up and tear-down. During tear-down, it is suggested that exhibitors stay with their exhibit until empty cartons are delivered and goods are packed, sealed and properly labelled.

To reduce the risk of theft, the Ontario Dental Association strongly advises that all valuable goods (especially those which may be easily concealed), be removed from the exhibit floor each day at the conclusion of the show. Televisions, computers and other electronic devices are also particularly vulnerable to theft. The Ontario Dental Association recommends that all remaining goods be covered with a fire-retardant cloth prior to leaving the floor each day.

Electrical Information

Electricity is not included with booth fees and may be ordered directly from SHOWTECH Power and Lighting.

- It is a requirement of Rule 2-022 of the Electrical Safety Code, a provincial regulation, that any electrical equipment which is being displayed, offered for sale or used in any show, convention or similar exhibition must be approved. The authority for enforcing this regulation is vested in the Electrical Safety Authority.
- It is the responsibility of each exhibitor to ensure that all electrical equipment in, on, or about his/her booth complies with the above regulation. This includes electrical merchandise as well as lighting and display equipment.
- Please contact SHOWTECH Power and Lighting with respect to dealing with electrical equipment for which approval is sought.
- One of the fundamental requirements for Canadian Standards Association certification is that appropriate approvals markings (CSA monogram or label) appear on each device. If such markings are missing, the device must be considered unapproved and, therefore, subject to special inspection and possible removal.
- If you wish to display, offer for sale, or use, any electrical equipment which is not now certified by the Canadian Standards Association, it is first necessary to submit same to the Electrical Safety Authority for approval by means of their special inspection services.
- Should any of this equipment not conform, it is recommended that you request temporary permission to exhibit while the necessary electrical approvals certification is being sought.
- Failure to comply with the above could result in the equipment being refused connection to the source of electrical supply and removal from the display.

Rules and Regulations

Fire Safety

Exhibitors must meet the requirements as set out in the Metro Toronto Convention Centre's Fire Regulations for Exhibitors. The requirements contained in the Fire Regulations for Exhibitors and the Ontario Fire Code will be strictly enforced by the Fire Safety Director of the Metro Toronto Convention Centre and the Toronto Fire Prevention Division. Exhibitors are required to complete and submit the Centre's "Fire Safety Reply" form.

All aisles must be kept clear and all exits to fire stairs unobstructed. All drapes, table coverings and paper used for decorating purposes must be fire-retardant. Dust covers, if required, must be supplied by the exhibitors and must be fire-retardant.

Professional Ethics and Standards with Respect to Exhibits

All exhibitors are required to conduct themselves within full compliance of the Canadian Health Protection Branch (HPB), Workplace Hazardous Materials Information System (WHMIS), and manufacturers' regulations, specifications and warranties related to the sale and distribution of health care products at the Ontario Dental Association's Annual Spring Meeting. Dental exhibitors selling outdated, distressed, incomplete or repackaged products regulated by Health Canada's Health Products and Food Branch, Therapeutic Products Directorate, Medical Devices Bureau, may lose their right to exhibit at future Ontario Dental Association Annual Spring Meetings.

All exhibitors are required to comply with Ontario Dental Association By-laws and/or Ontario Dental Association policy and must not exhibit and/or display such products or services that would constitute the promotion of a product known to be hazardous to health.

All exhibitors are expected to operate in a fair, respectful manner towards fellow exhibitors and the Ontario Dental Association. Interference with, sabotage of, or theft from another exhibit or the Ontario Dental Association is strictly prohibited and may be subject to penalties for extreme violations as listed above under the "Penalties for Violations" section on page 16.

Disclaimer

All matters not covered in these booth conditions are subject to the decision and control of the Education Advisory Committee of the Ontario Dental Association notwithstanding anything in the application for space or contained in these conditions. The Ontario Dental Association expressly reserves the right to change the dates or hours but not to reduce the aggregate time of the meeting; to transfer the meeting to another building if, for any reason, the Metro Toronto Convention Centre should not be available; to change the floor plan or alter the location and/or reduce the size of the Exhibitor's space, if in the opinion of the Ontario Dental Association's Education Advisory Committee, it should be necessary to do so.

Default by the Ontario Dental Association

If, for any reason, the exhibition cannot be held as proposed or the Ontario Dental Association fails to fulfill its commitments as set out in the enclosed provisions or contract, the Ontario Dental Association (it's members, officers, officials, agents and/or employees, and other participants, sponsors and advertisers) shall be released from any physical or monetary damage claim by reimbursing only the amounts received from exhibitors for booth space and sponsorship fees. The Ontario Dental Association shall not be held liable or responsible for any loss or inconvenience of any kind caused by the water system being shut down, a power outage, a disruption in heating, lighting, air conditioning, telecommunications or any other service for reasons beyond its control caused by war, strike, riot, crime, terrorism or an Act of God.

Privacy

The information collected from exhibitors will be used by the Ontario Dental Association for the purpose of processing your payments for exhibit space rental and for no other purpose. The Ontario Dental Association is committed to protecting the privacy of your personal information. Our privacy policy and further information regarding the collection, use and disclosure of personal information can be viewed at www.oda.ca or by contacting our Chief Privacy Officer: Tel: 416-922-3900 or 1-800-387-1393 E-mail: info@oda.ca



Booth Display Guidelines

Dimensions | Hanging Signs | Banners and Trusses Motorized Vehicles | Live Patient Demonstrations

The following booth guidelines and diagrams reflect the standards set by the *International Association for Exposition Management Guidelines for Display Rules and Regulations*. Since their introduction these International Guidelines have become the model for most domestic exhibitions.

- No two storey booths are permitted.
- All Island, Peninsula, and Full Aisle booth configurations and those booth configurations of 400 sq. ft. (4 booths) or more are required to **SUBMIT DRAWINGS OF THEIR BOOTH PLAN FOR APPROVAL BY THE ODA'S EDUCATION ADVISORY COMMITTEE BY FEB. 15, 2019**

Any variances from these guidelines must be approved by the Education Advisory Committee in writing. Any discrepancies from these published guidelines will have to be adjusted accordingly on-site.

Single Standard Regular Booth or Single Corner Booth

- The maximum height of the back wall of the exhibit is 12'0" (3.66m).
- The maximum height of any tables, counters or other exhibit fixtures or components in the first 5'0" (1.52m) from the aisle line is 4'0" (1.22m).
- The maximum height of any tables, counters or other exhibit fixtures or components in the back 5'0" (1.52m) from the aisle line is 12'0" (3.66m).

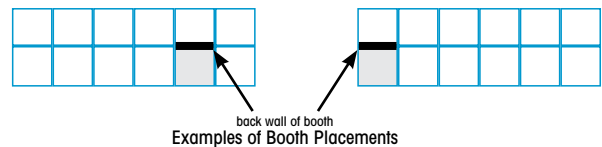
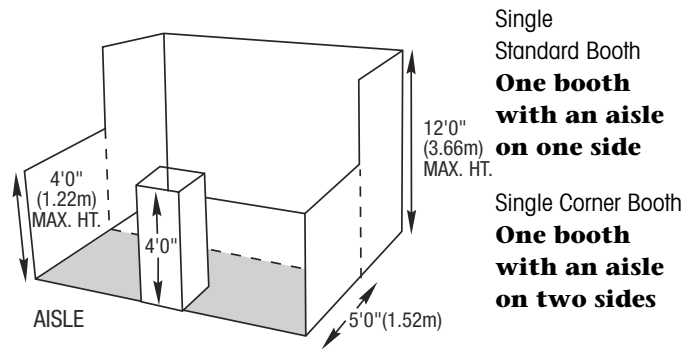

Hanging Signs

- Are **not** permitted over a single booth.

Multiple booths in a straight row and full aisle booths

Two or more booths in a straight line with an aisle on one side:

- The maximum height of the back wall of the exhibit is 12'0" (3.66m).
- The maximum height of any tables, counters or other exhibit fixtures or components in the first 5'0" (1.52m) from the aisle line is 4'0" (1.22m).
- The maximum height of any tables, counters or other exhibit fixtures or components in the back 5'0" (1.52m) from the aisle line is 12'0" (3.66m).

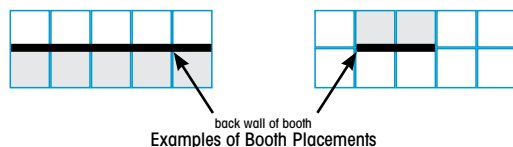
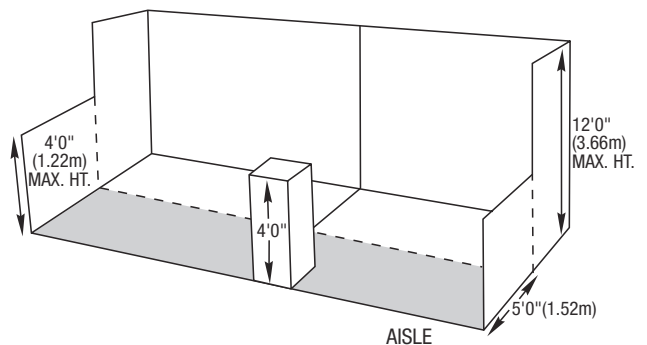

For Multiple or Full Aisle Booths consisting of 4 booths or more: **DRAWINGS OF THE PLAN MUST BE SUBMITTED FOR APPROVAL BY THE ODA'S EDUCATION ADVISORY COMMITTEE BEFORE FEB. 15, 2019.**

Booth Display Guidelines

Peninsula Booths

Four or more booths, which include two corner booths, plus two or more standard booths with an aisle on three sides.

Maximum height restrictions:

- The maximum height of any tables, counters or other exhibit fixtures or components in the centre back 10'0" (3.05m) of the booth is 18'0" (5.49m).
- The maximum height of any tables, counters or other exhibit fixtures or components in the first 3'0" (1.00m) from the aisle line is 4'0" (1.22m). An allowance may be made for such structures to rise to 12'0" (3.66m) in height if the middle section from 4'0" (1.22m) to 7'0" (2.13m) is see through/open to allow an unobstructed and clear view down the aisle.
- The maximum height of any tables, counters or other exhibit fixtures or components in the back 5'0" (1.52m) from the aisle line is 18'0" (5.49m).

DRAWINGS OF THE PLAN MUST BE SUBMITTED FOR APPROVAL BY THE ODA'S EDUCATION ADVISORY COMMITTEE BEFORE FEB. 15, 2019.

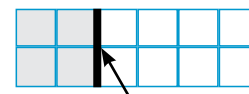
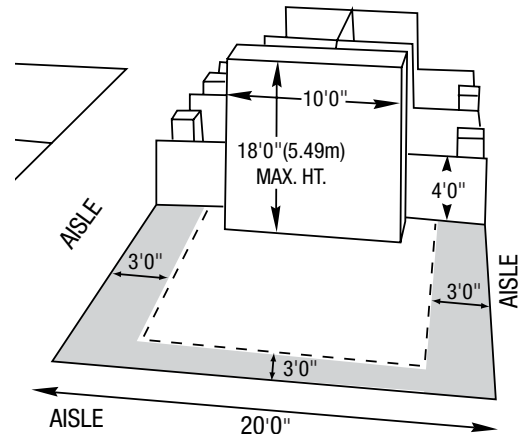

back wall of booth

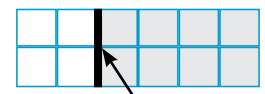

back wall of booth

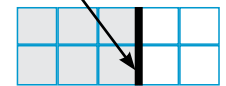

Island Booths

Four or more booths, which include four corner booths, with aisles on all four sides.

- As an island booth is automatically separated by the width of an aisle from all neighbouring exhibits, full use of the floorplan is permitted, with the exception that back walls are permitted on one side of the display only.
- **Maximum height restrictions for island booths with a back wall:**
If a back wall is used, the maximum height is 18'0" (5.49m) and the maximum width centrally located is 10'0" (3.05m).
- **Maximum height restrictions for island booths without a back wall:**
If a back wall is not used the maximum height of any tables, counters or other exhibit fixtures or components is 18'0" (5.49m).
- Freeform exhibits may extend to all outer edges of the booth space, but the design of the booth must allow for see-through visibility and accessibility from all four sides.
- The maximum height restrictions for any tables, counters or other exhibit fixtures or components in the first 3'0" (1.00m) from the aisle line is 4'0" (1.22m).
- An allowance may be made for such structures to rise to 12'0" (3.66m) in height if the middle section from 4'0" (1.22m) to 7'0" (2.13m) is see through/open to allow an unobstructed and clear view down the aisle.

DRAWINGS OF THE PLAN MUST BE SUBMITTED FOR APPROVAL BY THE ODA'S EDUCATION ADVISORY COMMITTEE BEFORE FEB. 15, 2019.

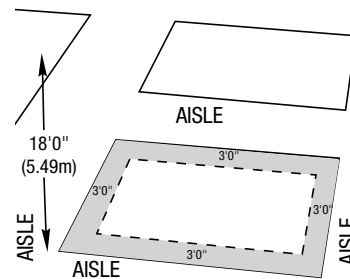

Island booth without a back wall

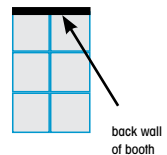

back wall of booth

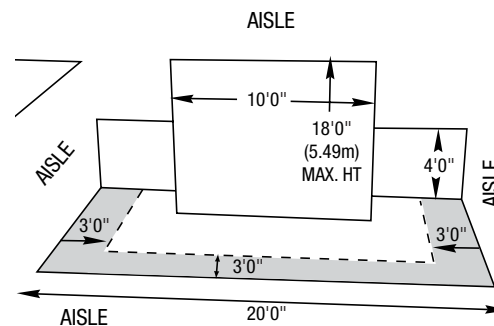

Island booth with a back wall

Booth Display Guidelines

Hanging Signs, Banners And Trusses

HANGING SIGNS, BANNERS AND TRUSSES

- Hanging signs, banners or trusses are **not** permitted on single regular or single corner booths.
- For all other booths, the top of any sign, banner or truss may not exceed 20'0" (6.1m) above the floor level.

Peninsula, Full Aisle, and Multiple Booths in a Straight Row

- See Figure 1. Sign, banner or truss width or diameter cannot exceed 50% of the corresponding dimension of the booth.
- Hanging signs and banners must be set back at least 25% of the width dimension from the back of the booth.
- The rear of a sign or banner must be covered or finished in such a manner as not to distract from those booths behind it.

Island Booths

- For island booths of 20' x 20' or greater, hanging sign, banner or truss may extend to all outer edges of the contracted booth space.

The Education Advisory Committee reserves the right to remove all signs, banners and trusses which are deemed to be objectionable by the Ontario Dental Association or its designates.

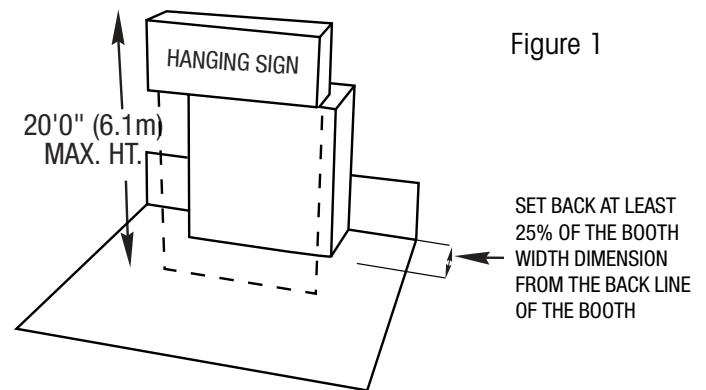

Figure 1

All signs, banners and trusses **MUST BE SUBMITTED FOR APPROVAL BY THE ODA'S EDUCATION ADVISORY COMMITTEE BEFORE FEB. 15, 2019.**



Live Demonstrations

- Demonstrations involving procedures on attendees or live models which are to be performed on the exhibit floor may not take place at any time during the Annual Spring Meeting without advance arrangements being made. Requests for approval **MUST BE SUBMITTED FOR APPROVAL BY THE ODA'S EDUCATION ADVISORY COMMITTEE BY FEB. 15, 2019.**

Professional Videotaping/Photography

- Exhibitors wishing to schedule professional photographers or videographers to photograph their own booth on-site at the ASM must make advance arrangements to do so. Requests for approval **MUST BE SUBMITTED FOR APPROVAL BY THE ODA'S EDUCATION ADVISORY COMMITTEE BY FEB. 15, 2019.**

Motorized Vehicles

- The Metro Toronto Convention Centre has specific requirements to be followed when a motorized vehicle is displayed at the Centre. Contact Vicky Hatzopoulos at the ODA, 416-355-2266 or vhatzopoulos@oda.ca for a copy of these guidelines.
- Motorized vehicles are **not** permitted in single regular or single corner booths.
- For all other booths, a motorized vehicle may be featured with the provision that the inclusion of this vehicle does not contravene any of the booth configuration guidelines for the booth involved.



Print Advertising Rates: Preliminary Guide

Mechanical Requirements

Printing Method: Full colour, CMYK, Offset lithography

Binding: Saddle-stitched (Preliminary Guide), Perfect Bound (Final Guide)

Screen: Halftone screen, 150 lpi (line screen)

Electronic Material: Digital files only. PDF/X-1a files. Other acceptable file formats include: eps, tiff (minimum resolution 300 dpi)

To ensure the accuracy of all advertisements, a full-size colour proof must be provided. Publisher shall not be liable for any advertisements received without a colour proof.

Submissions: Email to vhatzopoulos@oda.ca

See: Terms and Conditions page 24

Preliminary Guide Advertising Rates

	SIZE	4-Colour	B & W
1 Full Page (Trim) Full Page (Bleed)	8.125" x 10.875" 8.375" x 11.125"	\$2,400	\$1,500
2 1/2 Page 3 - horizontal or - vertical	7.5" x 4.75" 3.4375" x 9.875"	1,500	950
4 1/4 Page 5 - vertical or - horizontal	7.5" x 2.25" 3.5" x 1.75"	1,050	550
6 1/8 Page 7 - horizontal or - vertical	7.5" x 0.9916" 3.4375" x 2.25"	650	350

COVERS (4-Colour only)

OBC (Trim)	8.125" x 10.875"	\$3,300	—
OBC (Bleed)	8.375" x 11.125"		
IFC/IBC (Trim)	8.125" x 10.875"	3,100	—
IFC/IBC (Bleed)	8.375" x 11.125"		

Preliminary Guide Space Closing
October 26, 2018

Preliminary Guide Material Closing
November 12, 2018

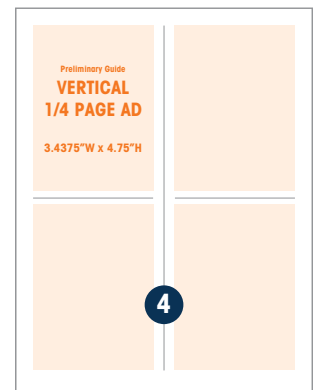
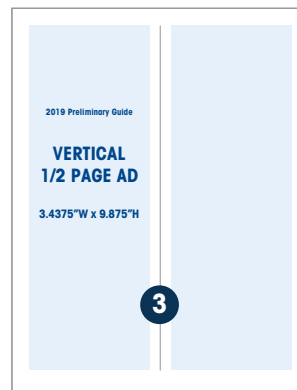
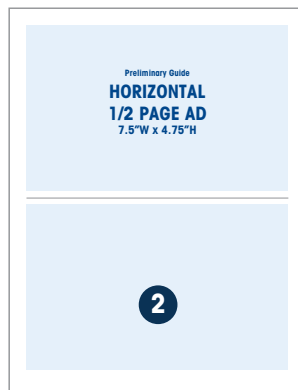
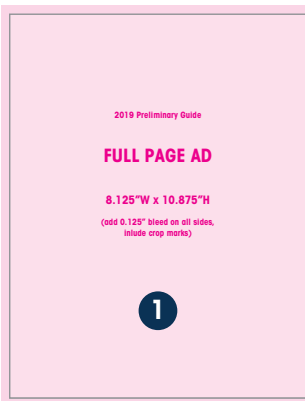

Discounted combination rates are available – please contact us for details!

DIMENSIONS	
Full Page (Trim)	8.125" x 10.875"
Full Page (Bleed)	8.375" x 11.125"
1/2 Page Horizontal	7.5" x 4.75"
1/2 Page Vertical	3.4375" x 9.875"
1/4 Page Horizontal	3.5" x 1.75"
1/4 Page Vertical	7.5" x 2.25"
1/8 Page Horizontal	7.5" x 0.9916"
1/8 Page Vertical	3.4375" x 2.25"

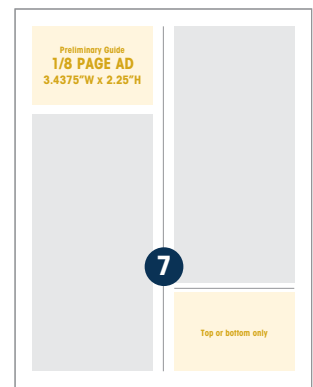
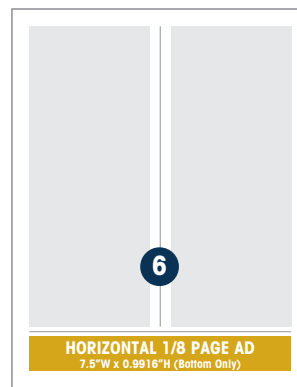

Print Advertising Rates: Final Program

Final Program Advertising Rates

		SIZE		4-Colour	B & W
7	Full Page (Trim)	4.5"	x	9"	\$3,100
	Full Page (Bleed)	4.75"	x	9.25"	
8	½ Page Horizontal	3.5"	x	3.5"	2,100
9	¼ Page Horizontal	3.5"	x	1.75"	1,200

COVERS (4-Colour only)					
OBC (Trim)	4.5"	x	9"	\$4,100	—
OBC (Bleed)	4.75"	x	9.25"		
IFC/IBC (Trim)	4.5"	x	9"	3,900	—
IFC/IBC (Bleed)	4.75"	x	9.25"		



Terms and Conditions

• 2019 Preliminary Guide and Final Program advertisers must be exhibitors at the 2019 ASM.

- Payment in full is due at time of space closing. All published rates are subject to 13% HST.
- Cancellations and space changes will not be accepted after the closing dates.

Publisher Conditions: Advertising material is subject to approval by the Ontario Dental Association.

See: Mechanical Requirements on page 23

Final Program Space Closing
March 11, 2019

Final Program Material Closing
March 29, 2019

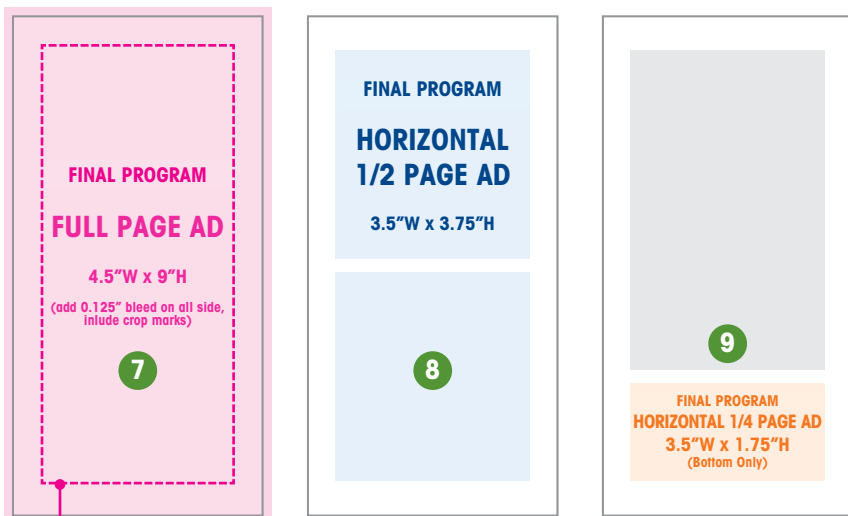

Discounted combination rates are available – please contact us for details!

	DIMENSIONS
Full Page (Trim)	4.5" x 9"
Full Page (Bleed)	4.75" x 9.25"
½ Page Horizontal	3.5" x 3.5"
¼ Page Horizontal	3.5" x 1.75"

PLEASE NOTE: LIVE AREA Full page ad 3.67" x 8.25"

(see dashed pink area) See following page for detailed information.

May 9–11, 2019

Metro Toronto Convention Centre
South Building

ASM19

To learn more about our exciting sponsorship and advertising opportunities, please contact:

Helen McDowell

Conference and Events Manager
Ontario Dental Association
Phone: 416-355-2274 Fax: 416-922-9571
hmcowell@oda.ca

Vicky Hatzopoulos

Exhibits and Sponsorship Coordinator
Ontario Dental Association
Phone: 416-355-2266 Fax: 416-922-9571
vhatzopoulos@oda.ca

Detailed Ad Specs: Final Program

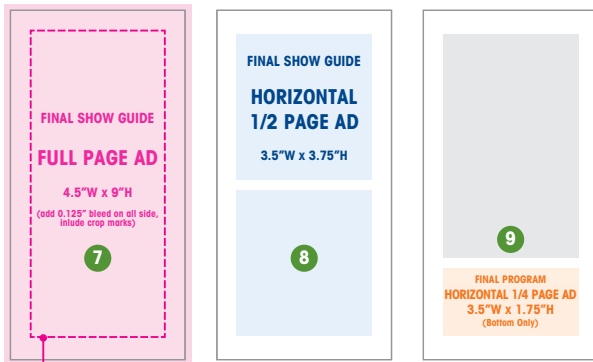

TRIM EDGE OF PAGE

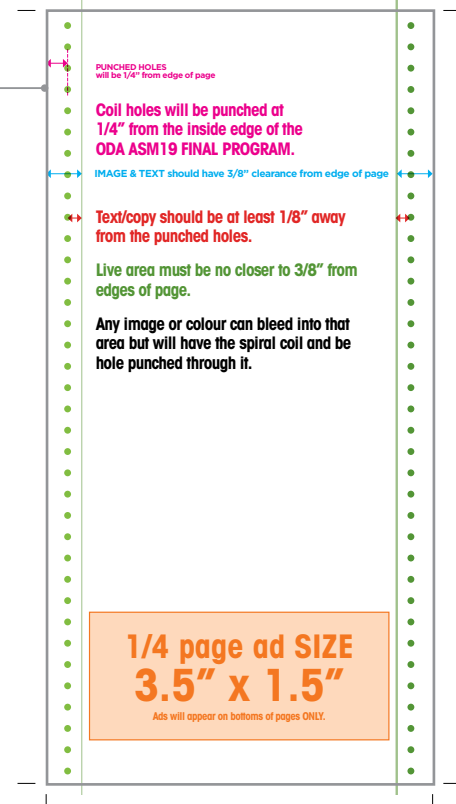
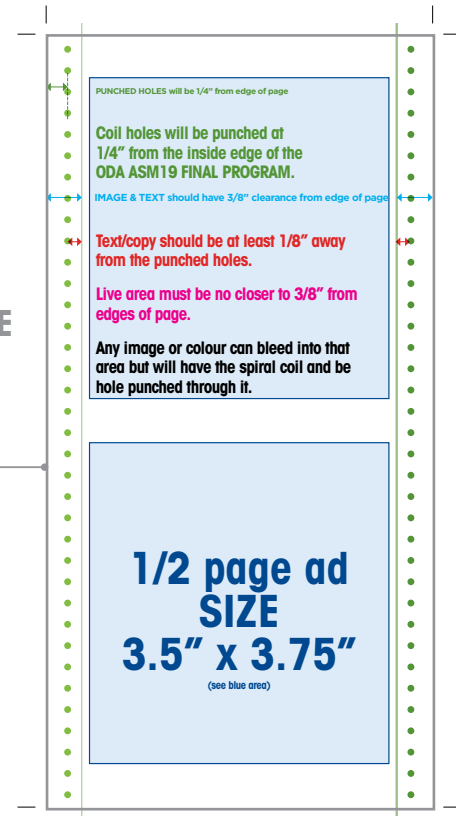

PLEASE NOTE: LIVE AREA

